

100G / 120G SKID STEER LOADER

Service leads users, Quality drives the future



MAXBULL



What is a Maxbull Skid Steer Loader used for?



MAIN SPECIFICATIONS

型号	Model		100G	120G
额定载重	Rated load capacity	(kg)	1200	1500
铲斗容积	Bucket capacity	(m ³)	0.6	0.7
倾翻载荷	Tipping load	(kg)	2200	2400
提升力	Lifting force	(kg)	2550	3100
工作流量	Hydraulic pump flow	(L/min)	120	144
发动机型号&功率	Engine model & power	(HP)	Weichai WP4.1G100E311 engine (100hp)	Weichai WP4.1G140E301 engine (140hp)
操作重量	Operating weight	(kg)	3550	3600
最大行驶速度	Max. travel speed	(km/h)	12 / 18	12 / 18
最大爬坡度	Grade ability	(°)	20	20
轮胎规格	Tire size		12-16.5	12-16.5
油箱容积 (燃油/液压油)	Refill capacity (Fuel tank / Hydraulic tank)		90 / 90	90 / 90

DIMENSIONS

最大操作高度	Height at Max. extension	A (mm)	4070	4070
铰接销高度	Hinge pin height	B (mm)	3150	3150
总高度 (至驾驶室顶部)	Overall height	C (mm)	2160	2160
带斗总长度	Overall length (with bucket)	D (mm)	3560	3580
无斗总长度	Overall length (without bucket)	E (mm)	2880	2880
带斗宽度	Overall width (with bucket)	F (mm)	1880	1880
轮距	Tread	G (mm)	1500	1500
轴距	Wheel base	H (mm)	1185	1185
离地间隙	Ground clearance	J (mm)	260	260
倾倒角度	Dumping angle	K (°)	40	40
最大卸载高度	Max. dumping height	L (mm)	2450	2450
卸载距离	Reach @ max. dumping height	M (mm)	700	710

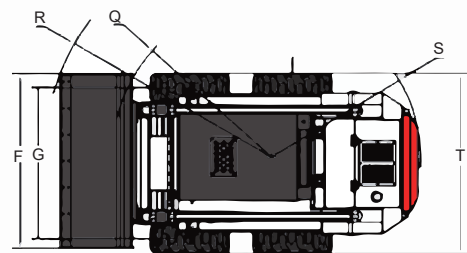
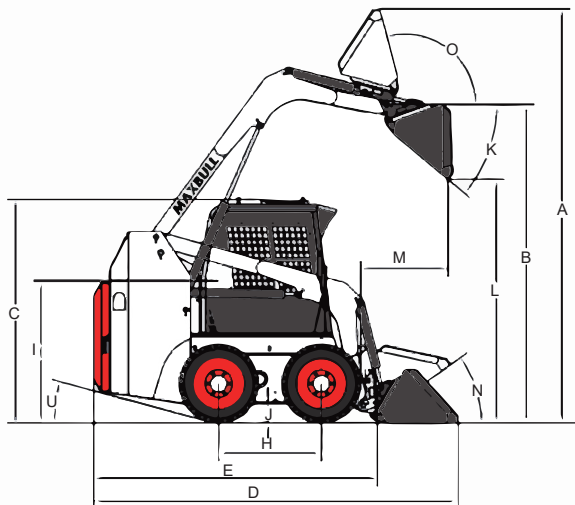

Anhui Maxbull Machinery Technology Co., Ltd.

ADD: No.199 Jinxiu Street, Shushan District, Hefei, Anhui, China.
 TEL: 0086 551 63852627
 Email: info@maxbull.cn
 WEB: www.ahmaxbull.com

Authorized dealer:

