

# 45G / 60G

## SKID STEER LOADER

Service leads users, Quality drives the future



# MAXBULL



### What is a Maxbull Skid Steer Loader used for?



## MAIN SPECIFICATIONS

型号	Model		45G	60G
额定载重	Rated load capacity	(kg)	700	850
铲斗容积	Bucket capacity	(m <sup>3</sup> )	0.4	0.5
倾翻载荷	Tipping load	(kg)	1400	1700
提升力	Lifting force	(kg)	1950	1950
工作流量	Hydraulic pump flow	(L/min)	75	75
发动机型号&功率	Engine model & power	(HP)	Xinchai C490 engine (50hp)	Xinchai A498BPG engine (60hp)
操作重量	Operating weight	(kg)	3100	3240
最大行驶速度	Max. travel speed	(km/h)	12	12
最大爬坡度	Grade ability	(°)	20	20
轮胎规格	Tire size		10-16.5	12-16.5
油箱容积 (燃油/液压油)	Refill capacity (Fuel tank / Hydraulic tank)		65 / 65	80 / 80

## DIMENSIONS

最大操作高度	Height at Max. extension	A (mm)	3980	4000
铰接销高度	Hinge pin height	B (mm)	3080	3100
总高度 (至驾驶室顶部)	Overall height	C (mm)	2050	2160
带斗总长度	Overall length (with bucket)	D (mm)	3420	3490
无斗总长度	Overall length (without bucket)	E (mm)	2640	2750
带斗宽度	Overall width (with bucket)	F (mm)	1740	1880
轮距	Tread	G (mm)	1450	1500
轴距	Wheel base	H (mm)	991	991
离地间隙	Ground clearance	J (mm)	185	205
倾倒角度	Dumping angle	K (°)	40	40
最大卸载高度	Max. dumping height	L (mm)	2380	2400
卸载距离	Reach @ max. dumping height	M (mm)	750	750

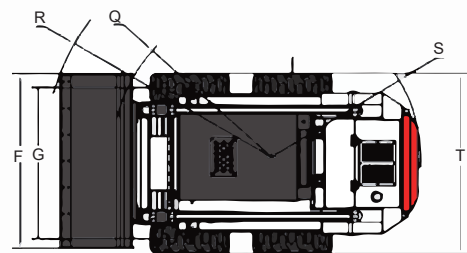
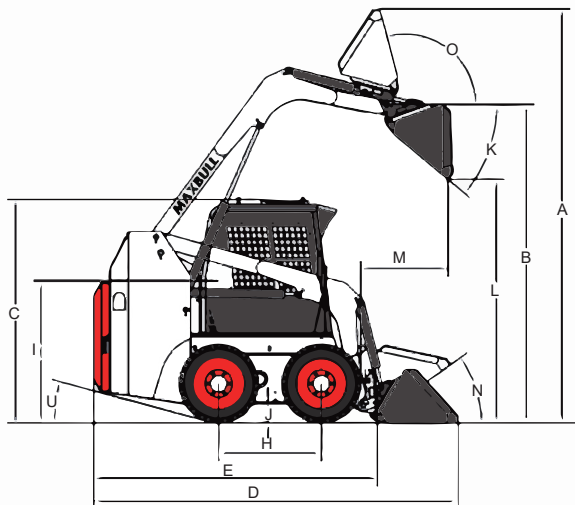

### Anhui Maxbull Machinery Technology Co., Ltd.

ADD: No.199 Jinxiu Street, Shushan District, Hefei, Anhui, China.  
 TEL: 0086 551 63852627  
 Email: info@maxbull.cn  
 WEB: www.ahmaxbull.com

Authorized dealer:

