

制造商和技术参数		Manufacturer and technical parameters			
特性		Characteristics			
1.01	制造商	HELI			
1.02	型号	CPC(D)10	CPC(D)15	CPC(D)18	
1.03	额定负荷	kg	1000	1500	1800
1.04	负载中心	mm	500		
1.05	动力种类	柴油Diesel			
1.06	驾驶方式	座驾式Sit-on type			
1.07	整机自重	kg	2290	2700	2920
轮胎		Tyre			
2.01	前轮/后轮	Tyre(front/rear)			
尺寸		Size			
3.01	最大起升高度(标准)	Max.lifting height	H	mm	
3.02	门架全高(货叉落地、门架垂直)	Mast height,lowered	H1	mm	
3.03	货叉起升最大难度(带挡货架)	Mast height,extended	H2	mm	
3.04	自由提升高度	Free lift	H3	mm	
3.05	最小转弯半径	Min.Turning radius	HR	mm	
3.06	全长(含货叉/不含货叉)	Overall length(with fork/without fork)	L	mm	
3.07	全宽	Overall width	W	mm	
3.08	全高(护顶架)	Overall height(overhead guard)	H4	mm	
3.09	轴距	Wheel base	L1	mm	
3.10	轮距(前轮距/后轮距)	Tread (front/rear)	W3/W4	mm	
3.11	前悬距	Front overhang	L2	mm	
3.12	最小离地间隙(门架处)	Min.Ground clearance	H5	mm	
3.13	座椅上表面距护顶架距离	Distance from the seat surface to the overhead guard	H6	mm	
3.14	叉距(外侧)(最大/最小)	Distance across forks(max./min.)	W5	mm	
3.15	最小直角通道宽度	Min.Right angle aisle width	Ra	mm	
3.16	门架倾角	Mast tilt	α/β	°	
3.17	货叉尺寸	Fork size	mm	770x100x32	920x100x35
性能		Performance			
4.01	起升速度(满载/空载)	Lghting speed:loaded/unloaded	mm/s	500/530	
4.02	下降速度(满载/空载)	Lowering speed:loaded/unloaded	mm/s	≤600/≥300	
4.03	行驶速度(满载/空载)	Travelling speed:loaded/unloaded	Km/h	14.5/14.5	
4.04	满载爬坡速度	Gradeability(loaded)	%	23(22)	
4.05	最大牵引力(满载/空载)	Max/traction force:loaded/unloaded	KN	10.1/8.4	
驱动、传动控制装置		Drive and transmission control device			
5.01	蓄电池(电压/容量)	Battery voltage/capacity	V/Ah	12/18	
5.02	发动机制造商/型号	Internal combustion engine model		全柴V25-45V42	新昌4D29V41
5.03	发动机额定功率	Internal combustion engine rated output	kW/rpm	33.1/2600	36.8/2500
5.04	发动机额定扭矩	Internal combustion engine rated torque	Nm/rpm	150/1600-1800	165/1600-1800
5.05	缸数-缸径-行程	Internal combustion engine number of cylinder		4-90x100	4-93x105
5.06	发动机排量	Engine displacement	L	2.5	2.9
5.07	发动机燃油箱容量	Internal combustion engine fuel tank capacity	L	30	30
5.08	排放标准	Emission		国IV(内销)	国IV(内销)
5.09	变速箱变速档数(前/后形式)	Transmission number of speed fwd/bwd type		1-1自动挡1-1Power Shift T/M/2-2手动换挡2-2Manual ShiftT/M	

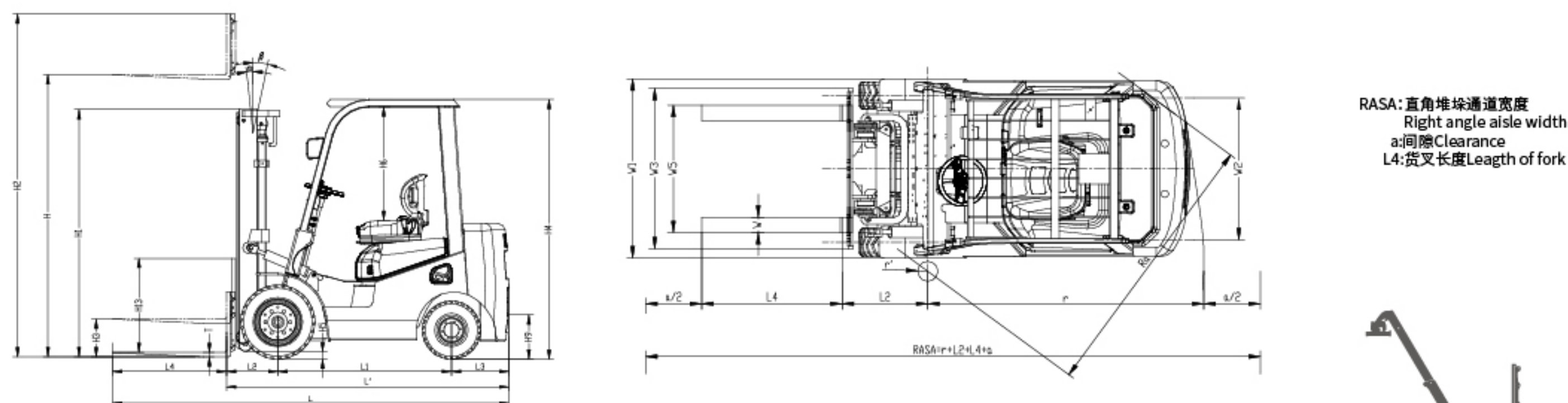

合力产品范围: 1-46吨内燃叉车;0.6-18吨电动叉车;前移式叉车、托盘车、堆垛车等仓储类产品;
AGV/智能搬运车及系统解决方案;正面吊、堆高机、牵引车、防爆叉车、越野叉车、装载机多样化产品。



宝鸡合力叉车有限公司
BAOJI HELI FORKLIFT CO.,LTD.
地址 / 陕西省宝鸡市金台区宝福路127号
电话 / 0917-3571231 (营销部)
传真 / 0917-3668884 (营销部)

网址 / <http://www.helichina.com/bjhl/>
E-MAIL / bjhl@helichina.com

* 本公司保留更改产品设计和规格的权利,恕不另行通知。
* Our products are subject to improvements and changes without notice.

1-1.8 t

K2系列内燃平衡重式叉车

K2 series Internal Combustion Counterbalanced Forklift Truck



» 整车优势 FEATURES OF THE COMPLETED TRUCK

- ▶ 整机外观简洁流畅,富有时代感
The appearance of the whole machine is simple and smooth, with a sense of The Times.
- ▶ 配置四缸水冷发动机,整机动力性能优越
Equipped with four cylinder water - cooled engine, the over all power performance is superior.
- ▶ 高置进气口和大通道进气系统,延长发动机寿命
High air intake and large channel air intake system, prolong engine life.
- ▶ 采用整体位延成行引擎罩,强度更好
The whole position is extended into a row of engine hood, better strength.
- ▶ 合理的人机工程,操纵更加轻松舒适
Reasonable man-machine engineering, more easy and comfortable operation.
- ▶ 新型方向盘调整机构,舒适性更高
New steering wheel adjustment mechanism, higher comfort.



LED灯具 LEDluminaire



国四排放动力 Power of emission



可靠的转向桥 Reliable steering bridge



宽视野门架 Wide view mast



新式机罩 The new hood



液晶仪表 LCD meters

选装配置 Optional

可选属具	Available attachment	可选配置	Optional
侧移器	Side shifter	驾驶室	Driver' scab
倾翻叉	Tipping fork	高排气	High air exhausting device
卷子夹	Paper roll clamp	灭火器	Fire extinguisher
宽视野二级全自由门架	Wide view free-lift mast(two-stage)	后工作灯	Rear working lamp
宽视野三级全自由门架	Wide view free-lift mast(three-stage)	实心轮胎	Solid tyre
		警示灯	Warning light

宽视野基本型门架 WIDE VIEW MAST

门架型号 mast model	最大起升高度 Max. lifting height (mm)	承载能力(载荷中心为500mm)(kg) load capacity (load center 500mm)			门架全高 (货叉落地)(mm) mast overall height (fork to the ground)	门架倾角 (前/后)(°) mast tilt angle front/real	整车自重 (kg) service weight		
		CPC(D)10	CPC(D)15	CPC(D)18			CPC(D)10	CPC(D)15	CPC(D)18
M200	2000	1000	1500	1750	1495	6/12	2188	2608	2828
M250	2500	1000	1500	1750	1745	6/12	2214	2634	2854
M300	3000	1000	1500	1750	1995	6/12	2240	2660	2880
M330	3300	1000	1500	1750	2145	6/12	2255	2675	2895
M350	3500	1000	1500	1750	2245	6/12	2265	2685	2905
M370	3700	1000	1500	1750	2345	6/6	2275	2695	2915
M400	4000	1000	1500	1700	2545	6/6	2305	2724	2944
M425	4250	1000	1400	1650(*1750)	2670	6/6 *6/12	2317	2737	2957
M450	4500	950	1350	1550(*1700)	2795	6/6 *6/12	2329	2749	2969
M500	5000	930	1000(*1250)	1000(*1600)	3045	6/6 *6/6	2355	2775	2995
M550	5500	900	900(*1500)	950(*1500)	3345	6/6 *3/6	2392	2812	3032
M600	6000	600(*850)	600(*1050)	600(*1400)	3595	6/6 *3/6	2418	2838	3058

二级全自由门架 WIDE VIEW FULL FREE 2-STAGE MAST

门架型号 mast model	最大起升高度 Max. lifting height (mm)	承载能力(载荷中心为500mm)(kg) load capacity (load center 500mm)			门架全高 (货叉落地)(mm) mast overall height (fork to the ground)	门架倾角 (前/后)(°) mast tilt angle front/real	整车自重 (kg) service weight		
		CPC(D)10	CPC(D)15	CPC(D)18			CPC(D)10	CPC(D)15	CPC(D)18
ZM200	2000	1000	1500	1750	1495	6/12	2188	2608	2828
ZM250	2500	1000	1500	1750	1745	6/12	2200	2620	2840
ZM300	3000	1000	1500	1750	1995	6/12	2240	2660	2880
ZM330	3300	1000	1500	1750	2145	6/12	2252	2672	2892
ZM350	3500	1000	1500	1750	2245	6/12	2263	2683	2903
ZM370	3700	1000	1500	1750	2345	6/6	2373	2693	2913
ZM400	4000	1000	1500	1700	2545	6/6	2281	2701	2921
ZM425	4250	1000	1400	1650(*1750)	2670	6/6 *6/12	2278	2698	2918
ZM450	4500	950	1350	1550(*1700)	2795	6/6 *6/12	2283	2703	2923
ZM500	4750	930	1000(*1600)	1000(*1600)	3045	6/6 *6/6	2300	2720	2940
ZM550	5500	900	900(*1150)	950(*1500)	3345	*3/6	2321	2741	2961
ZM600	6000	600(*850)	600(*1050)	600(*1400)	3595	*3/6	2343	2763	2983

三级全自由门架 WIDE VIEW FULL FREE 3-STAGE MAST

门架型号 mast model	最大起升高度 Max. lifting height (mm)	承载能力(载荷中心为500mm)(kg) load capacity (load center 500mm)			门架全高 (货叉落地)(mm) mast overall height (fork to the ground)	门架倾角 (前/后)(°) mast tilt angle front/real	整车自重 (kg) service weight		
		CPC(D)10	CPC(D)15	CPC(D)18			CPC(D)10	CPC(D)15	CPC(D)18
ZSM360	3600	1000	1450	1750	1790	6/6	2302	2742	2942
ZSM400	4000	1000	1400	1600	1925	6/6	2311	2751	2951
ZSM435	4350	950	1300	1500(*1700)	2040	6/6 *6/6	2362	2802	3002
ZSM450	4500	950	1300	1500(*1650)	2090	6/6 *6/6	2380	2820	3020
ZSM470	4700	930	1280	1450(*1600)	2160	6/6 *6/6	2385	2825	3025
ZSM480	4800	920	1250	1400(*1580)	2190	6/6 *6/6	2398	2838	3038
ZSM500	5000	900	1000(*1250)	1000(*1550)	2290	6/6 *6/6	2350	2790	2990
ZSM540	5400	750(*900)	800(*1150)	800(*1480)	2415	6/6 *3/6	2370	2810	3010
ZSM600	6000	550(*850)	550(*1050)	550(*1380)	2640	6/6 *6/6	2393	2833	3033
ZSM650	6500	*850	*1000	*1250	2840	3/3 *3/3	2428	2676	3068
ZSM700	7000	*650	*750	*900	3025	*3/3	2468	2716	3108

注: 1、*为双胎对应的额定载重量
2、表中自重为双胎重量: +110kg

Note: 1:* refers to rated capacity with double tyres.
2:The service weight is the weight of truck with dual tyres:+110kg.