

MAXBULL

**CPD15/18/20/25
/30/35/38**

A3LiH4-M A7LiH4-S A7XLiH4-S

MAXBULL

Anhui Maxbull Machinery Technology Co., Ltd.

ADD: No. 2628 Hubei Road, Baohe District, Hefei, Anhui, China

TEL: 0086 551 63852627

Email: info@maxbull.cn

WEB: www.ahmaxbull.com



1.5-3.8 t **LITHIUM**

H4 series Lithium-ion Battery
Forklift Truck

Stable and Reliable

CAE analysis, component bench test and whole truck strengthening test are used to ensure reliability.

Reliable components

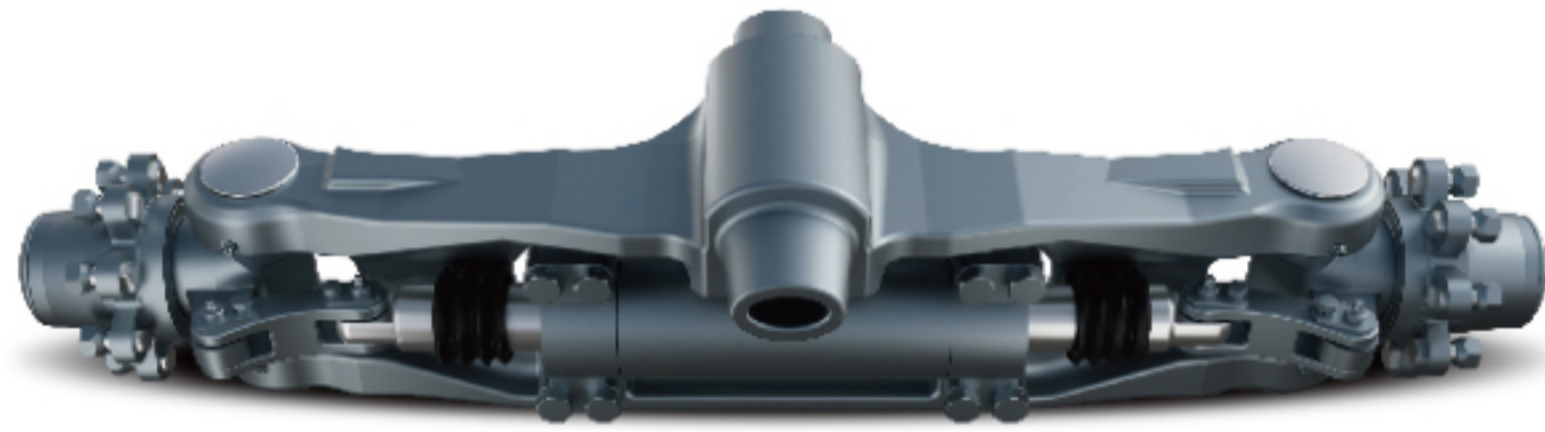

Steering axle:
Cast axle body, tapered roller bearing

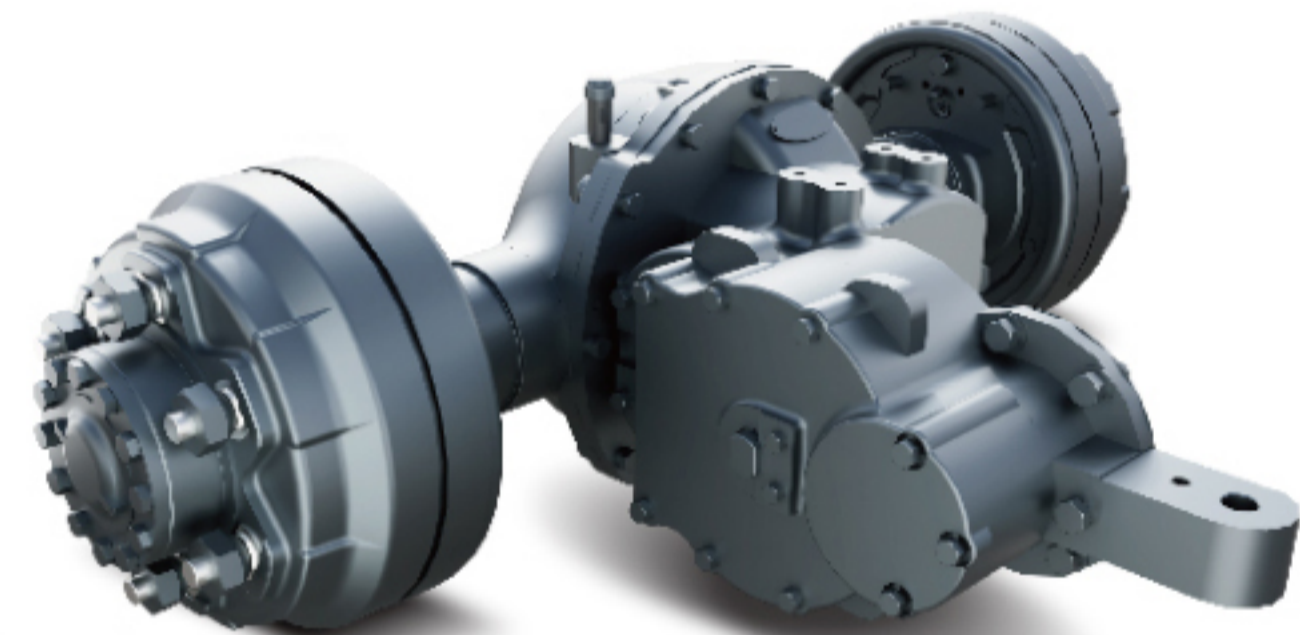

Drive axle:
integral brake drum, integral cast axle housing, half shaft oil seal design, high-precision gear with large coincidence



Right set operating valve stem offers good operation comfort.

Intelligent color screen instrument offers more friendly human-computer interaction.



Graphical interface design / Chinese fault display / integrated handheld unit function / optional integrated vehicle networking function

Full package design of instrument panel; Water cup holder, mobile phone storage space, USB interface (optional for S, standard for M)

Good lateral stability of the whole truck and guaranteed safety during operation

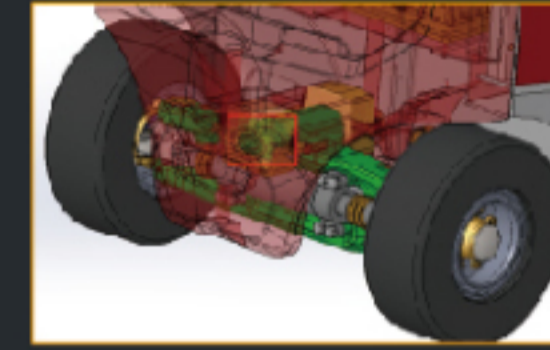

High rotation point steering axle

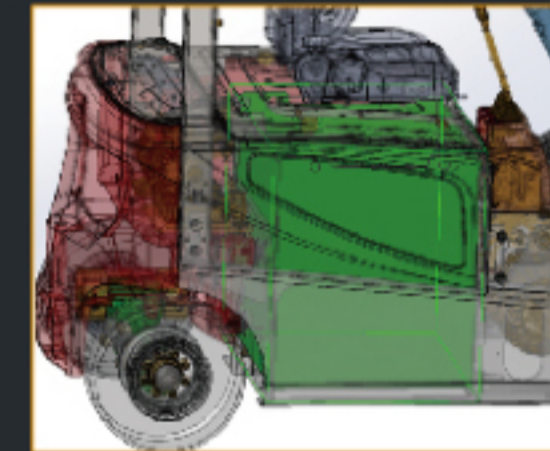

Middle and sink layout of the battery

Good heat dissipation

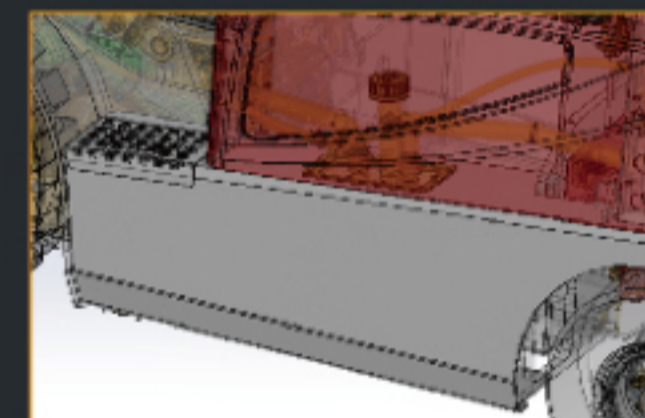

Side mounted welded oil tank



Test verification



Rain test

Simulate the operation under 15min rainstorm, reach IPx4 protection grade, and meet the needs of outdoor operation.



Cold storage test

The whole truck can run continuously after 6 hours of alternating operation in the -20 °C cold storage and 12 hours of parking in the cold storage.



Vehicle vibration test

The vibration frequency of the whole truck is tested to optimize and improve the operating comfort.



Reliability endurance test

800 hour strengthening of the whole truck (including climbing, rain, bumpy road, etc.).

Intelligent security

Intelligent control and protection improve the safety of drivers.

- Dual core controller
- OPS protection
(standard driving OPS / optional hydraulic OPS)
- Hydraulic burst protection, forward tilting self-locking protection
- Electrical multiple protection
(short circuit protection, overheat protection, low power protection, sequence protection)
- Parking safety reminder
- Reminder through slow sliding on ramp
- Turning automatic deceleration (optional)

- Flexible battery charging mode (can be charged with the truck or replaced)
- Pump, pump motor, controller and other main electrical components are located on the counterweight, which is convenient for maintenance.
- Friendly interface

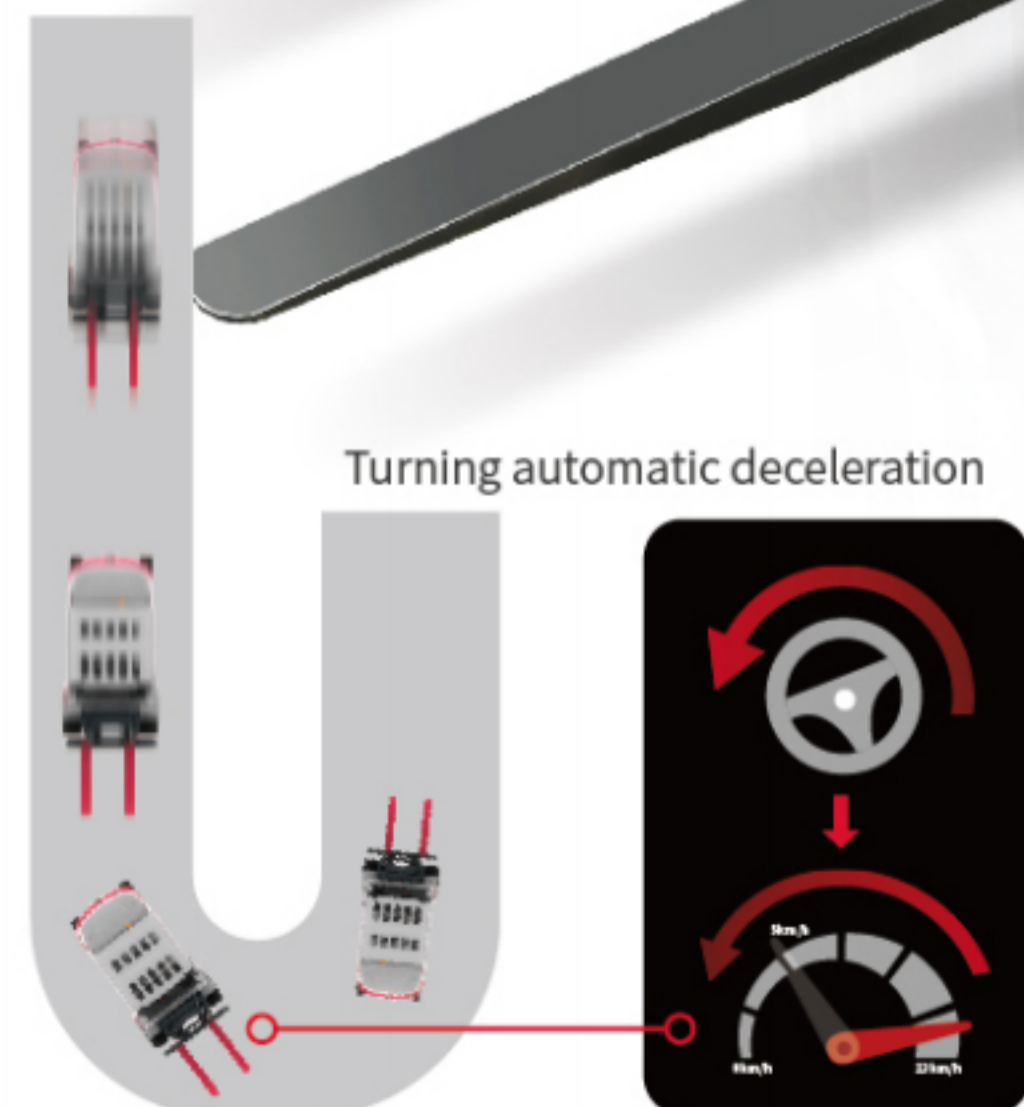

 **Driver Presence Sensing System** **Unmanned self-locking intelligent protection**

Convenient maintenance

More convenient maintenance operation improves the maintenance efficiency of after-sale services.

Manufacturer and Technical Data (Tabulation 1)

| Characteristics | | MAXBULL | | | | |
|----------------------|---|-----------------|-------|----------------------|-------------|----------------|
| 1.01 | Manufacturer | | | | | |
| 1.02 | Model | CPD15 | CPD18 | CPD15 | CPD18 | CPD20 |
| 1.03 | Configuration number | A3LiH4-M | | A7LiH4-S | | A7XLiH4-S |
| 1.04 | Rated capacity | Q | kg | 1500 | 1800 | 2000 |
| 1.05 | Load center distance | c | mm | 500 | | |
| 1.06 | Power mode | Lithium battery | | | | |
| 1.07 | Driving mode | Seated | | | | |
| 1.08 | Front overhang | x | mm | 409 | 409 | 414 |
| 1.09 | Wheelbase | y | mm | 1475 | 1475 | |
| Weight | | | | | | |
| 2.01 | Total weight (with/without battery) | | kg | 2855/2675 | 2970/2790 | 2835/2672 |
| 2.02 | Axle load (laden, front/rear) | | kg | 3719/636 | 4203/567 | 3711/624 |
| 2.03 | Axle load (unladen, front/rear) | | kg | 1294/1561 | 1293/1677 | 1287/1548 |
| Tyres | | | | | | |
| 3.01 | Tyre type | | | Pneumatic tyre | | Pneumatic tyre |
| 3.02 | Tyre size, front | | | 6.50-10-10PR | | 6.50-10-12PR |
| 3.03 | Tyre size, rear | | | 16x6-8-10PR | | 16x6-8-10PR |
| 3.04 | Wheels, number front/rear (x=driven wheels) | | | 2/2 | | 2/2 |
| 3.05 | Tread, front | b10 | mm | 934 | 934 | 934 |
| 3.06 | Tread, rear | b11 | mm | 920 | 920 | 920 |
| Dimensions | | | | | | |
| 4.01 | Mast tilt angle (forward/backward) | α/β | ° | 6/8 | | 6/8 |
| 4.02 | Height (mast lowered) | h1 | mm | 1995 | 1995 | 1995 |
| 4.03 | Free lifting height | h2 | mm | 155 | 155 | 155 |
| 4.04 | Lifting height (standard) | h3 | mm | 3000 | 3000 | 3000 |
| 4.05 | Max. height, extended (with backrest) | h4 | mm | 4014 | 4014 | 4014 |
| 4.06 | Height of overhead guard | h6 | mm | 2130 | 2130 | 2130 |
| 4.07 | Seat height relating to SIP (to ground) | h7 | mm | 1125 | 1125 | 1125 |
| 4.08 | Towing coupling height | h10 | mm | 250 | 250 | 250 |
| 4.09 | Overall length (with fork) | l1 | mm | 3120 | 3120 | 3125 |
| 4.10 | Overall length (without fork) | l2 | mm | 2200 | 2200 | 2205 |
| 4.11 | Overall width | b1 | mm | 1120 | 1120 | 1120 |
| 4.12 | Fork size: thickness x width x length | | | 2A | | 2A |
| 4.13 | Fork carriage, according to ISO2328 | s/e/l | mm | 35x100x920 | 35x100x920 | 40x100x920 |
| 4.14 | Distance across fork-arms, Max./Min. | b5 | mm | 960/200 | 960/200 | 960/200 |
| 4.15 | Ground clearance (at mast) | m1 | mm | 100 | 100 | 100 |
| 4.16 | Ground clearance (center of wheelbase) | m2 | mm | 95 | 95 | 95 |
| 4.17 | Right angle stacking aisle width for pallet 1000x1200mm crossways | Ast | mm | 3575 | 3575 | 3580 |
| 4.18 | Right angle stacking aisle width for pallet 800x1200mm lengthways | Ast | mm | 3770 | 3770 | 3775 |
| 4.19 | Min. outside turning radius | Wa | mm | 1920 | 1920 | 1920 |
| Performance data | | | | | | |
| 5.01 | Travel speed (laden/unladen) | | km/h | 14.5/15 | | 12/13 |
| 5.02 | Lift speed (laden/unladen) | | m/s | 0.320/0.440 | 0.290/0.440 | 0.270/0.400 |
| 5.03 | Lowering speed (laden/unladen) | | m/s | 0.400/0.400 | | 0.400/0.400 |
| 5.04 | Max. drawbar pull (laden) | | N | 10200/9700 | 10200/9800 | 11000/10700 |
| 5.05 | Max. gradeability (laden/unladen) | | % | 17/27 | 15/26 | 15/25 |
| 5.06 | Acceleration time (10 m) (laden/unladen) | | s | 5.5/5.2 | 5.6/5.3 | 6.0/5.7 |
| Battery | | | | | | |
| 6.01 | Battery voltage/Capacity | | V/Ah | 80/150 | 80/125 | 80/150 |
| 6.02 | Battery weight | | kg | 180 | 163 | 180 |
| Motor and controller | | | | | | |
| 7.01 | Driving motor powering (S2-60min) | | kW | 8 | 8 | 8 |
| 7.02 | Lifting motor powering (S3-15%) | | kW | 10.6 | 10.6 | 10.6 |
| 7.03 | Driving motor controlling mode | | | MOSFET/AC | | |
| 7.04 | Lifting motor controlling mode | | | MOSFET/AC | | |
| Addition data | | | | | | |
| 8.01 | Service brake/Parking brake | | | Hydraulic/Mechanical | | |
| 8.02 | Operating pressure for attachments | | Mpa | 16 | | |

Manufacturer and Technical Data (Tabulation 2)

| Characteristics | | MAXBULL | | | | | | | | | |
|----------------------|---|-----------------|-------|----------------------|-------------|-------------|-------------|--------------------------------------|-------------|-------------|--|
| 1.01 | Manufacturer | | | | | | | | | | |
| 1.02 | Model | CPD20 | CPD25 | CPD20 | CPD25 | CPD30 | CPD35 | CPD30 | CPD35 | CPD38 | |
| 1.03 | Configuration number | A3LiH4-M | | A7LiH4-S | | A3LiH4-M | | A7LiH4-S | | A7LiH4-S | |
| 1.04 | Rated capacity | Q | kg | 2000 | 2500 | 2000 | 2500 | 3000 | 3500 | 3800 | |
| 1.05 | Load center distance | c | mm | 500 | | | | | | | |
| 1.06 | Power mode | Lithium battery | | | | | | | | | |
| 1.07 | Driving mode | Seated | | | | | | | | | |
| 1.08 | Front overhang | x | mm | 460 | | 477 | 482 | 477 | 482 | 482 | |
| 1.09 | Wheelbase | y | mm | 1660 | | 1750 | | 1750 | | 1780 | |
| Weight | | | | | | | | | | | |
| 2.01 | Total weight (with/without battery) | | kg | 3585/3395 | 3925/3735 | 3540/3375 | 3880/3715 | 4550/4310 | 4860/4620 | 4500/4290 | |
| 2.02 | Axle load (laden, front/rear) | | kg | 4970/615 | 5790/635 | 4940/600 | 5760/620 | 6750/800 | 7630/730 | 6710/790 | |
| 2.03 | Axle load (unladen, front/rear) | | kg | 1750/1835 | 1780/2145 | 1720/1820 | 1750/2130 | 2050/2500 | 2110/2750 | 2010/2490 | |
| Tyres | | | | | | | | | | | |
| 3.01 | Tyre type | | | Pneumatic tyre | | | | Front Pneumatic tyre/Rear Solid tyre | | | |
| 3.02 | Tyre size, front | | | 7.00-12-14PR | | | | 28x9-15-14PR | | | |
| 3.03 | Tyre size, rear | | | 18x7-8-14PR | | | | 18x7-8 | | | |
| 3.04 | Wheels, number front/rear (x=driven wheels) | | | 2/2 | | | | 2/2 | | | |
| 3.05 | Tread, front | b10 | mm | 970 | 970 | 970 | 970 | 1000 | 1000 | 1080 | |
| 3.06 | Tread, rear | b11 | mm | 960 | 960 | 960 | 960 | 970 | 970 | 970 | |
| Dimensions | | | | | | | | | | | |
| 4.01 | Mast tilt angle (forward/backward) | α/β | ° | 6/10 | | | | 6/10 | | | |
| 4.02 | Height (mast lowered) | h1 | mm | 2000 | 2070 | 2120 | 2070 | 2120 | 2180 | 2180 | |
| 4.03 | Free lifting height | h2 | mm | 165 | 165 | 155 | 155 | 160 | 160 | 160 | |
| 4.04 | Lifting height (standard) | h3 | mm | 3000 | 3000 | 3000 | 3000 | 3000 | 3000 | 3000 | |
| 4.05 | Max. height, extended (with backrest) | h4 | mm | 4320 | 4217 | 4217 | 4217 | 4217 | 4217 | 4217 | |
| 4.06 | Height of overhead guard | h6 | mm | 2170 | 2170 | 2180 | 2180 | 2185 | 2185 | 2185 | |
| 4.07 | Seat height relating to SIP (to ground) | h7 | mm | 1154 | 1164 | 1164 | 1164 | 1164 | 1164 | 1164 | |
| 4.08 | Towing coupling height | h10 | mm | 300 | 300 | 310 | 310 | 310 | 310 | 310 | |
| 4.09 | Overall length (with fork) | l1 | mm | 3354 | 3504 | 3354 | 3504 | 3637 | 3642 | 3637 | |
| 4.10 | Overall length (without fork) | l2 | mm | 2434 | 2567 | 2572 | 2567 | 2572 | 2572 | 2612 | |
| 4.11 | Overall width | b1 | mm | 1180 | 1260 | 1260 | 1260 | 1260 | 1260 | 1392 | |
| 4.12 | Fork size: thickness x width x length | | | 2A | | | | 3A | | | |
| 4.13 | Fork carriage, according to ISO2328 | s/e/l | mm | 40x122x920 | 40x122x1070 | 40x122x920 | 40x122x1070 | 45x125x1070 | 50x125x1070 | 45x125x1070 | |
| 4.14 | Distance across fork-arms, Max./Min. | b5 | mm | 1030/250 | 1060/250 | 1060/250 | 1060/250 | 1060/250 | 1060/250 | 1060/250 | |
| 4.15 | Ground clearance (at mast) | m1 | mm | 100 | 110 | 110 | 110 | 110 | 110 | 125 | |
| 4.16 | Ground clearance (center of wheelbase) | m2 | mm | 125 | 135 | 135 | 135 | 135 | 135 | 140 | |
| 4.17 | Right angle stacking aisle width for pallet 1000x1200mm crossways | Ast | mm | 3753 | 3912 | 3917 | 3912 | 3912 | 3917 | 3952 | |
| 4.18 | Right angle stacking aisle width for pallet 800x1200mm lengthways | Ast | mm | 3953 | 4115 | 4117 | 4115 | 4117 | 4117 | 4152 | |
| 4.19 | Min. outside turning radius | Wa | mm | 2140 | 2235 | 2235 | 2235 | 2235 | 2235 | 2270 | |
| Performance data | | | | | | | | | | | |
| 5.01 | Travel speed (laden/unladen) | | km/h | 14.5/15 | | 12/13 | | 14.5/15 | | 12/13 | |
| 5.02 | Lift speed (laden/unladen) | | m/s | 0.320/0.440 | 0.290/0.440 | 0.290/0.400 | 0.270/0.400 | 0.320/0.440 | 0.290/0.440 | 0.290/0.400 | |
| 5.03 | Lowering speed (laden/unladen) | | m/s | 0.360/0.460 | | 0.400/0.400 | | 0.400/0.400 | | 0.400/0.400 | |
| 5.04 | Max. drawbar pull (laden) | | N | 13600/13000 | 14000/13300 | 13600/13000 | 14000/13300 | 16300/15800 | 17000/16600 | 16300/16000 | |
| 5.05 | Max. gradeability (laden/unladen) | | % | 17/26 | 15/25 | 15/25 | 15/25 | 17/26 | 15/23 | 15/25 | |
| 5.06 | Acceleration time (10 m) (laden/unladen) | | s | 5.9/5.0 | 6.1/5.0 | 6.0/5.3 | 6.2/5.3 | 5.7/5.1 | 6.1/5.2 | 5.8/5.3 | |
| Battery | | | | | | | | | | | |
| 6.01 | Battery voltage/Capacity | | V/Ah | 80/202 | 80/150 | 80/250 | 80/250 | 80/202 | 80/250 | 80/250 | |
| 6.02 | Battery weight | | kg | 190 | 165 | 240 | 240 | 210 | 240 | 240 | |
| Motor and controller | | | | | | | | | | | |
| 7.01 | Driving motor powering (S2-60min) | | kW | 11 | | 15 | | 15 | | 16 | |
| 7.02 | Lifting motor powering (S3-15%) | | kW | 12 | | 16 | | 16 | | 16 | |
| 7.03 | Driving motor controlling mode | | | MOSFET/AC | | | | | | | |
| 7.04 | Lifting motor controlling mode | | | MOSFET/AC | | | | | | | |
| Addition data | | | | | | | | | | | |
| 8.01 | Service brake/Parking brake | | | Hydraulic/Mechanical | | | | | | | |
| 8.02 | Operating pressure for attachments | | Mpa | 16 | | | | | | | |

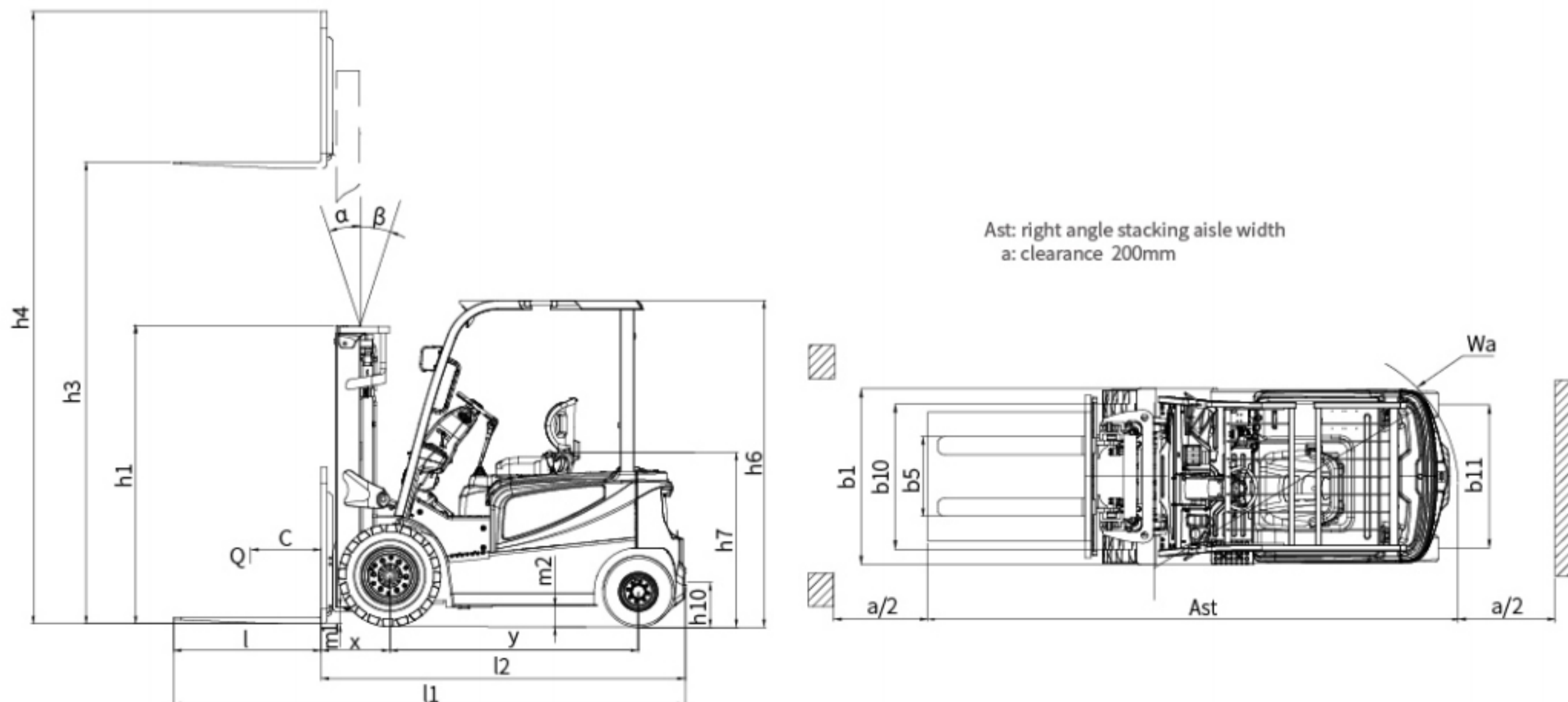

Load curve

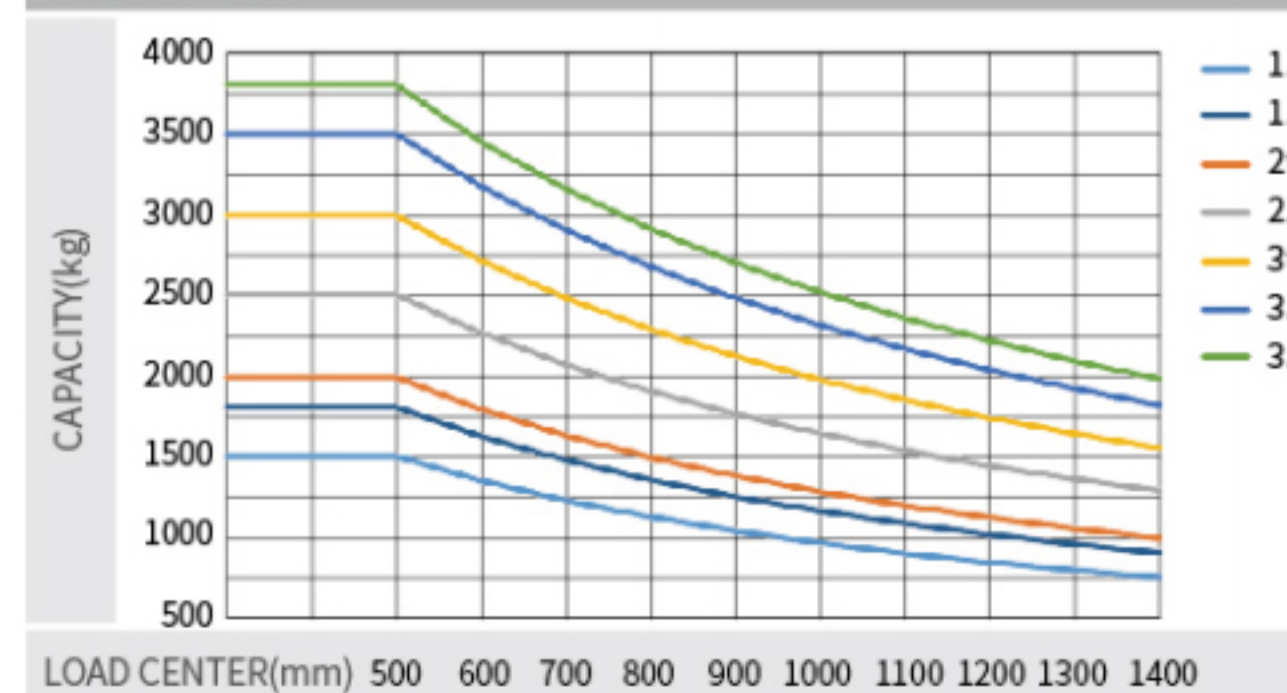

Note:

The vertical axis stands for load capacity and the horizontal axis stands for load center which is calculated from the front surface of the forks to the gravity of the standard load. The standard load means a cubic with 1000mm edge length. When mast is tilted forward, using non-standard forks or loading large goods, the load capacity will be reduced. The load capacity of standard mast at different load center can be known from this load chart.

| Lithium battery | | MAXBULL | | | | | | | | CATL | | | | | | | | | | |
|----------------------------|--|-----------|-----------|-----------|-----------|-----------|-----------|-----------|-----------|-----------|-----------|-----------|-----------|-----------|-----------|-----------|-----------|-----------|-----------|-----------|
| Battery brand | | 80V/125Ah | 80V/150Ah | 80V/202Ah | 80V/250Ah | 80V/280Ah | 80V/404Ah | 80V/560Ah | 80V/125Ah | 80V/150Ah | 80V/173Ah | 80V/202Ah | 80V/228Ah | 80V/271Ah | 80V/302Ah | 80V/346Ah | 80V/404Ah | 80V/456Ah | 80V/542Ah | 80V/604Ah |
| 1.5-1.8t S | | ● | ○ | ○ | ○ | ○ | — | — | ○ | ○ | ○ | ○ | ○ | ○ | ○ | — | — | — | — | — |
| 1.5-1.8t M | | — | ● | ○ | ○ | ○ | — | — | ○ | ○ | ○ | ○ | ○ | ○ | ○ | — | — | — | — | — |
| 2t (X) S | | — | ● | ○ | ○ | ○ | — | — | ○ | ○ | ○ | ○ | ○ | ○ | ○ | — | — | — | — | — |
| 2-2.5t S | | — | ● | ○ | ○ | ○ | — | — | ○ | ○ | ○ | ○ | ○ | ○ | ○ | — | — | — | — | — |
| 2-2.5t M | | — | — | ● | ○ | ○ | — | — | ○ | ○ | ○ | ○ | ○ | ○ | ○ | — | — | — | — | — |
| 3-3.5t S | | — | — | ● | ○ | ○ | — | — | ○ | ○ | ○ | ○ | ○ | ○ | ○ | ○ | ○ | ○ | ○ | ○ |
| 3-3.5t M | | — | — | — | ● | ○ | — | — | ○ | ○ | ○ | ○ | ○ | ○ | ○ | ○ | ○ | ○ | ○ | ○ |
| 3.8t S | | — | — | — | ● | ○ | — | — | ○ | ○ | ○ | ○ | ○ | ○ | ○ | ○ | ○ | ○ | ○ | ○ |
| Heating at low Temperature | | | | | | | | | | | | | | | | | | | | ● |

Note: ● standard; ○ optional; — non-configurable.

| Charger | | D80V100ALI-438 | |
|---------------------------------------|-----|---|--|
| Model | | Three-phase four-wiring type | |
| Wiring type | | 10 | |
| Power of charger | KVA | 32 | |
| Air switch model of Upper level power | A | 380±15% | |
| Input voltage range | Vac | <20A | |
| Input current | A | 5-100 | |
| Output current | A | For indoor use | |
| Protection level | | -20~+45 | |
| Working ambient temperature | °C | REMA320 | |
| Plugs and sockets | | Full charging time=required charging capacity/charging current+0.2h For example: the battery capacity is 80V/250Ah, and the discharging state is alarmed by instrument. The charger is 100A, thus the full charging time is 250*0.9/100+0.2≈2.45h | |

Lithium Battery Advantages

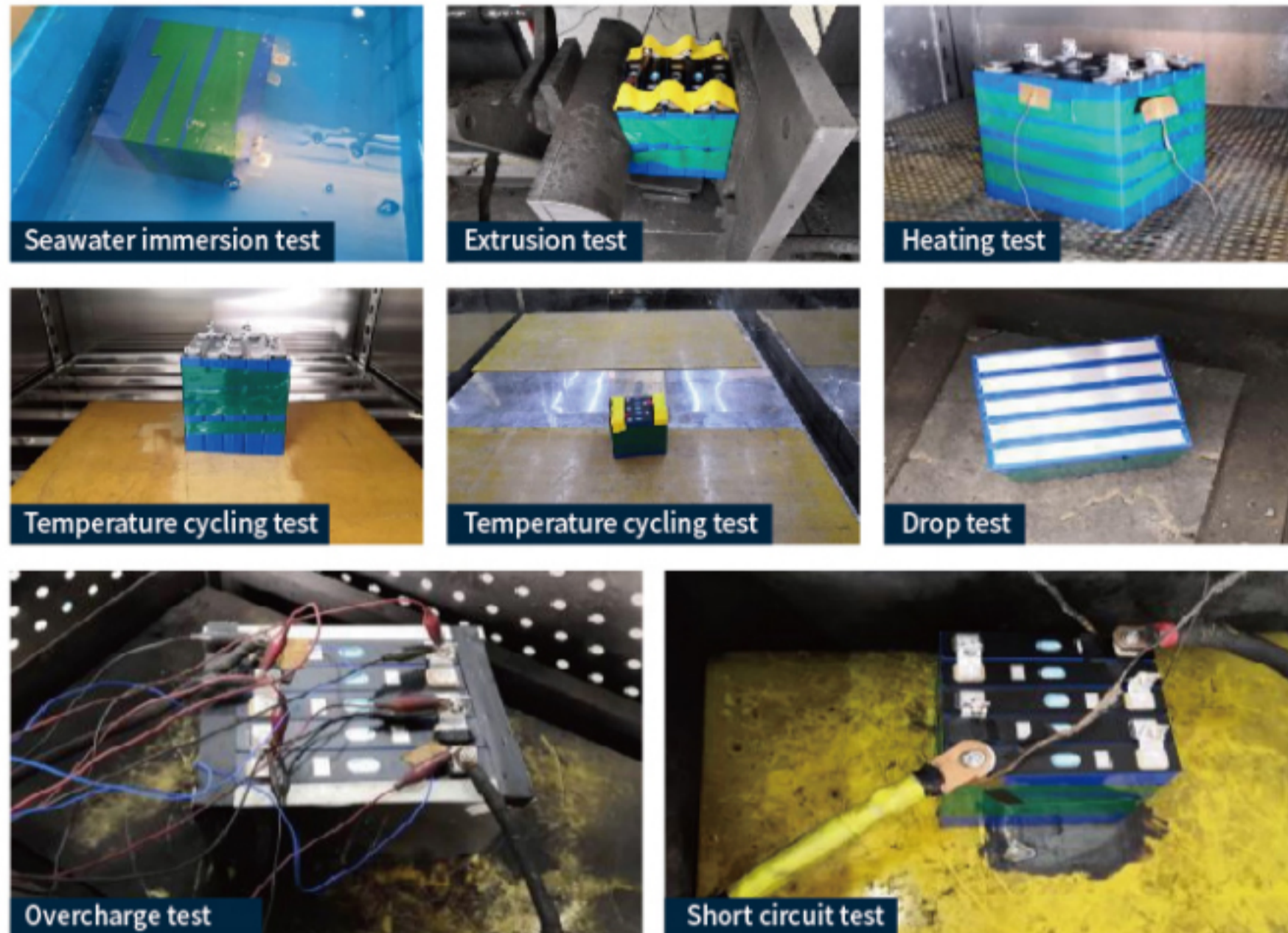

- The truck selects mature and economical square iron phosphate lithium battery core and module used by large numbers of commercial vehicles;
- The module adopts aluminum alloy plate frame, which is firm, light in weight and has good heat dissipation effect;
- Fast charging: fast charging makes truck gapless operation possible, and it can be filled in 2 hours;
- High efficiency and safety: The charging and discharging efficiency is up to 98%, and temperature of thermal runaway is over 600 °C;
- Low temperature adaptability: Standard configuration of heating function ensures normal operation of low temperature environment;
- Long service life: the normal charging and discharging cycles is more than 3000 times or 5 years, and capacity retention rate is more than 75%;
- Maintenance free: the battery does not need manual maintenance and does not need to add distilled water electrolyte;
- Green and clean: no pollution and zero emission.

Smart fleet management system (domestic basic edition)

| | |
|----------------------|---------------------------------------|
| Vehicle positioning | Statistical form |
| Remote diagnosis | Vehicle management |
| Remote monitoring | Identification recognition (optional) |
| Maintenance reminder | Weight management (optional) |
| Battery management | Collision management (optional) |



1.5t/1.8t/2t(E) Mast parameters

| Mast type | Mast model | Max.lifting height (mm) | Load capacity (lode center 500mm)(kg) | | | Height (mm) (mast lowered) | | Free lift (with backrest) (mm) | | Service weight (kg) | | | | | Mast tilt angle α/β (°) | |
|------------------------|------------|-------------------------|---------------------------------------|------|-------|----------------------------|-------|--------------------------------|--------|---------------------|--------|-------|----------|-------|-------------------------|-----|
| | | | 1.5t | 1.8t | 2t(E) | 1.5-1.8t | 2t(E) | 1.5t-S | 1.5t-M | 1.8t-S | 1.8t-M | 2t(E) | 1.5-1.8t | 2t(E) | | |
| 2-stage standard Mast | M200 | 2000 | 1500 | 1800 | 2000 | 1495 | 1495 | 155 | 155 | 2771 | 2791 | 2886 | 2905 | 3036 | 6/8 | 6/8 |
| | M250 | 2500 | 1500 | 1800 | 2000 | 1745 | 1745 | 155 | 155 | 2803 | 2823 | 2918 | 2938 | 3058 | 6/8 | 6/8 |
| | M300 | 3000 | 1500 | 1800 | 2000 | 1995 | 1995 | 155 | 155 | 2835 | 2855 | 2950 | 2970 | 3100 | 6/8 | 6/8 |
| | M330 | 3300 | 1500 | 1800 | 2000 | 2145 | 2145 | 155 | 155 | 2854 | 2874 | 2969 | 2989 | 3119 | 6/8 | 6/8 |
| | M350 | 3500 | 1500 | 1800 | 2000 | 2245 | 2245 | 155 | 155 | 2867 | 2887 | 2982 | 3002 | 3132 | 6/8 | 6/6 |
| | M370 | 3700 | 1500 | 1800 | 2000 | 2345 | 2345 | 155 | 155 | 2880 | 2900 | 2995 | 3015 | 3145 | 6/6 | 6/6 |
| | M400 | 4000 | 1500 | 1800 | 2000 | 2545 | 2545 | 155 | 155 | 2928 | 2948 | 3043 | 3063 | 3193 | 6/6 | 6/6 |
| | M425 | 4250 | 1500 | 1800 | 1950 | 2670 | 2670 | 155 | 155 | 2945 | 2965 | 3060 | 3080 | 3210 | 6/6 | 6/6 |
| | M450 | 4500 | 1450 | 1650 | 1750 | 2795 | 2795 | 155 | 155 | 2961 | 2981 | 3076 | 3096 | 3226 | 6/6 | 6/6 |
| | M500 | 5000 | 1200 | 1400 | 1500 | 3045 | 3045 | 155 | 155 | 2993 | 3013 | 3108 | 3128 | 3258 | 6/6 | 6/6 |
| | M550 | 5500 | 1250 | 1450 | 1300 | 3345 | 3345 | 155 | 155 | 3055 | 3075 | 3170 | 3190 | 3320 | 3/6 | 3/6 |
| | M600 | 6000 | 800 | 900 | 900 | 3595 | 3595 | 155 | 155 | 3087 | 3107 | 3202 | 3222 | 3352 | 3/6 | 3/6 |
| 2-stage full free mast | ZM200 | 2000 | 1500 | 1800 | 2000 | 1495 | 1495 | 485 | 485 | 2820 | 2840 | 2935 | 2955 | 3085 | 6/8 | 6/8 |
| | ZM250 | 2500 | 1500 | 1800 | 2000 | 1745 | 1745 | 735 | 735 | 2852 | 2872 | 2967 | 2987 | 3117 | 6/8 | 6/8 |
| | ZM300 | 3000 | 1500 | 1800 | 2000 | 1995 | 1995 | 985 | 985 | 2886 | 2906 | 3001 | 3021 | 3151 | 6/8 | 6/8 |
| | ZM330 | 3300 | 1500 | 1800 | 2000 | 2145 | 2145 | 1135 | 1135 | 2908 | 2928 | 3023 | 3043 | 3173 | 6/8 | 6/8 |
| | ZM350 | 3500 | 1500 | 1800 | 2000 | 2245 | 2245 | 1235 | 1235 | 2923 | 2943 | 3038 | 3058 | 3188 | 6/8 | 6/8 |
| | ZM370 | 3700 | 1500 | 1800 | 2000 | 2345 | 2345 | 1335 | 1335 | 2935 | 2955 | 3050 | 3070 | 3200 | 6/6 | 6/6 |
| | ZM400 | 4000 | 1500 | 1800 | 2000 | 2545 | 2545 | 1535 | 1535 | 2983 | 3003 | 3098 | 3118 | 3248 | 6/6 | 6/6 |
| | ZM425 | 4250 | 1500 | 1800 | — | 2670 | — | 1660 | — | 3002 | 3022 | 3117 | 3137 | — | 6/6 | — |
| | ZM450 | 4500 | 1450 | 1650 | — | 2795 | — | 1785 | — | 3021 | 3041 | 3136 | 3156 | — | 6/6 | — |
| | ZM500 | 5000 | 1200 | 1400 | — | 3045 | — | 2035 | — | 3055 | 3075 | 3170 | 3190 | — | 6/6 | — |
| | ZM550 | 5500 | 1250 | 1450 | — | 3345 | — | 2335 | — | 3116 | 3136 | 3231 | 3251 | — | 3/6 | — |
| | ZM600 | 6000 | 800 | 900 | — | 3595 | — | 2585 | — | 3150 | 3170 | 3265 | 3285 | — | 3/6 | — |
| 3-stage full free mast | ZSM360 | 3600 | 1500 | 1800 | 2000 | 1790 | 1790 | 785 | 785 | 2934 | 2954 | 3049 | 3069 | 3199 | 6/6 | 6/6 |
| | ZSM400 | 4000 | 1500 | 1800 | 2000 | 1925 | 1925 | 920 | 920 | 2958 | 2978 | 3073 | 3093 | 3223 | 6/6 | 6/6 |
| | ZSM435 | 4350 | 1450 | 1700 | 1850 | 2040 | 2040 | 1035 | 1035 | 2983 | 3003 | 3098 | 3118 | 3248 | 6/6 | 6/6 |
| | ZSM450 | 4500 | 1500 | 1750 | 1750 | 2090 | 2090 | 1085 | 1085 | 2994 | 3014 | 3109 | 3129 | 3259 | 6/6 | 6/6 |
| | ZSM470 | 4700 | 1400 | 1600 | 1650 | 2160 | 2160 | 1155 | 1155 | 3010 | 3010 | 3105 | 3125 | 3255 | 6/6 | 6/6 |
| | ZSM480 | 4800 | 1350 | 1550 | 1650 | 2190 | 2190 | 1185 | 1185 | 3017 | 3037 | 3132 | 3152 | 3282 | 6/6 | 6/6 |
| | ZSM500 | 5000 | 1300 | 1500 | 1500 | 2290 | 2290 | 1285 | 1285 | 3038 | 3058 | 3153 | 3173 | 3303 | 6/6 | 6/6 |
| | ZSM540 | 5400 | 1200 | 1400 | 1300 | 2415 | 2415 | 1410 | 1410 | 3064 | 3084 | 3179 | 3199 | 3329 | 3/6 | 3/6 |
| | ZSM600 | 6000 | 800 | 900 | 900 | 2640 | 2640 | 1635 | 1635 | 3136 | 2855 | 3251 | 3271 | 3401 | 3/6 | 3/6 |
| | ZSM650 | 6500 | 1100 | 1250 | — | 2840 | — | 1835 | — | 3174 | 3194 | 3289 | 3305 | — | 3/3 | — |
| | ZSM700 | 7000 | 900 | 950 | — | 3025 | — | 2025 | — | 3212 | 3232 | 3327 | 3347 | — | 3/3 | — |

Note: *Indicates the rated load capacity of the front wheel with twin tyres; 2t (E) indicates that the truck type is CPD20-ATXLIH4-S; When the front wheels of 1.5-1.8t are twin tyres (pneumatic tyres) and twin tyres (solid tyres), the service weight is increased by 58kg and 104kg respectively according to the table data.
2-stage full free mast:1.5-2t(E):When there is no backrest, the free lifting height increases by 379mm.
3-stage full free mast:1.5-2t(E):When there is no backrest, the free lifting height increases by 484mm.

2t/2.5t Mast parameters

| Mast type | Mast model | Max.lifting height (mm) | Load capacity (lode center 500mm)(kg) | | | Height (mm) (mast lowered) | | Free lift (with backrest) | | Service weight (kg) | | | | | Mast tilt angle α/β (°) | |
|------------------------|------------|-------------------------|---------------------------------------|------|------|----------------------------|--------|---------------------------|------|---------------------|--------|--------|------|------|-------------------------|--|
| | | | 2t | 2.5t | 2t | 2-2.5t | 2-2.5t | 2t-S | 2t-M | 2.5t-S | 2.5t-M | 2-2.5t | | | | |
| 2-stage standard Mast | M200 | 2000 | 2000 | 2500 | 1500 | 1500 | 150 | 3460 | 3505 | 3800 | 3845 | 3845 | 3845 | 6/10 | 6/10 | |
| | M250 | 2500 | 2000 | 2500 | 1750 | 1750 | 150 | 3508 | 3553 | 3848 | 3893 | 3893 | 3893 | 6/10 | 6/10 | |
| | M300 | 3000 | 2000 | 2500 | 2000 | 2000 | 150 | 3540 | 3585 | 3880 | 3925 | 3925 | 3925 | 6/10 | 6/10 | |
| | M330 | 3300 | 2000 | 2500 | 2150 | 2150 | 150 | 3580 | 3625 | 3920 | 3965 | 3965 | 3965 | 6/10 | 6/10 | |
| | M350 | 3500 | 2000 | 2500 | 2250 | 2250 | 150 | 3599 | 3644 | 3939 | 3984 | 3984 | 3984 | 6/10 | 6/10 | |
| | M370 | 3700 | 2000 | 2500 | 2350 | 2350 | 150 | 3615 | 3660 | 3955 | 4000 | 4000 | 4000 | 6/6 | 6/6 | |
| | M400 | 4000 | 2000 | 2500 | 2550 | 2550 | 150 | 3687 | 3732 | 3972 | 4017 | 4017 | 4017 | 6/6 | 6/6 | |
| | M425 | 4250 | 2000 | 2500 | 2675 | 2675 | 150 | 3711 | 3756 | 4051 | 4096 | 4096 | 4096 | 6/6 | 6/6 | |
| | M450 | 4500 | 1900 | 2300 | 2800 | 2800 | 150 | 3733 | 3778 | 4073 | 4118 | 4118 | 4118 | 6/6 | 6/6 | |
| | M500 | 5000 | 1800 | 2100 | 3050 | 3050 | 150 | 3777 | 3822 | 4117 | 4162 | 4162 | 4162 | 6/6 | 6/6 | |
| | M550 | 5500 | 1850 | 2200 | 3350 | 3350 | 150 | 3868 | 3913 | 4208 | 4253 | 4253 | 4253 | 3/6 | 3/6 | |
| | M600 | 6000 | 1550 | 1850 | 3600 | 3600 | 150 | 3913 | 3958 | 4253 | 4298 | 4298 | 4298 | 3/6 | 3/6 | |
| 2-stage full free mast | ZM200 | 2000 | 2000 | 2500 | 1500 | 1500 | 496 | 3727 | 3772 | 4067 | 4112 | 4112 | 4112 | 6/10 | 6/10 | |
| | ZM250 | 2500 | 2000 | 2500 | 1750 | 1750 | 746 | 3793 | 3838 | 4133 | 4178 | 4178 | 4178 | 6/10 | 6/10 | |
| | ZM300 | 3000 | 2000 | 2500 | 2000 | 2000 | 996 | 3860 | 3905 | 4200 | 4245 | 4245 | 4245 | 6/10 | 6/10 | |
| | ZM330 | 3300 | 2000 | 2500 | 2150 | 2150 | 1146 | 3900 | 3945 | 4240 | 4285 | 4285 | 4285 | 6/10 | 6/10 | |
| | ZM350 | 3500 | 2000 | 2500 | 2250 | 2250 | 1246 | 3927 | 3972 | 4267 | 4312 | 4312 | 4312 | 6/10 | 6/10 | |
| | ZM370 | 3700 | 2000 | 2500 | 2350 | 2350 | 1346 | 3953 | 3998 | 4293 | 4338 | 4338 | 4338 | 6/6 | 6/6 | |
| | ZM400 | 4000 | 2000 | 2500 | 2550 | 2550 | 1546 | 4044 | 4089 | 4384 | 4429 | 4429 | 4429 | 6/6 | 6/6 | |
| | ZM425 | 4250 | 1950 | 2450 | 2675 | 2675 | 1671 | 4077 | 4122 | 4417 | 4462 | 4462 | 4462 | 6/6 | 6/6 | |
| | ZM450 | 4500 | 1900 | 2400 | 2800 | 2800 | 1796 | 4110 | 4155 | 4450 | 4495 | 4495 | 4495 | 6/6 | 6/6 | |
| | ZM500 | 5000 | 1800 | 2200 | 3050 | 3050 | 2046 | 4177 | 4222 | 4517 | 4562 | 4562 | 4562 | 6/6 | 6/6 | |
| | ZM550 | 5500 | 1450 | 1550 | 3350 | 3350 | 2346 | 4294 | 4339 | 4634 | 4679 | 4679 | 4679 | 3/6 | 3/6 | |
| | ZM600 | 6000 | 1200 | 1300 | 3600 | 3600 | 2596 | 4361 | 4406 | 4701 | | | | | | |

| 3t/3.5t/3.8t Mast parameters | | | | | | | | | | | | | | | | | |
|------------------------------|------------|-------------------------|---------------------------------------|------|------|----------------------------|------|------|--------------------------------|------|------|---------------------|------|--------|----------------------|--------|--------|
| Mast type | Mast model | Max.lifting height (mm) | Load capacity (load center 500mm)(kg) | | | Height (mast lowered) (mm) | | | Free lift (with backrest) (mm) | | | Service weight (kg) | | | Mast tilt angle/β(°) | | |
| | | | 3t | 3.5t | 3.8t | 3t | 3.5t | 3.8t | 3t | 3.5t | 3.8t | 3t-S | 3t-M | 3.5t-S | | 3.5t-M | 3.8t-S |
| 2-stage standard Mast | M200 | 2000 | 3000 | 3500 | 3800 | 1570 | 1620 | 1680 | 155 | 160 | 160 | 4404 | 4454 | 4704 | 4754 | 5134 | 6/10 |
| | M250 | 2500 | 3000 | 3500 | 3800 | 1820 | 1870 | 1930 | 155 | 160 | 160 | 4452 | 4502 | 4757 | 4807 | 5187 | 6/10 |
| | M300 | 3000 | 3000 | 3500 | 3800 | 2070 | 2120 | 2180 | 155 | 160 | 160 | 4500 | 4550 | 4810 | 4860 | 5240 | 6/10 |
| | M330 | 3300 | 3000 | 3500 | 3800 | 2220 | 2270 | 2330 | 155 | 160 | 160 | 4529 | 4579 | 4842 | 4892 | 5272 | 6/10 |
| | M350 | 3500 | 3000 | 3500 | 3800 | 2320 | 2370 | 2430 | 155 | 160 | 160 | 4548 | 4598 | 4863 | 4913 | 5293 | 6/10 |
| | M370 | 3700 | 3000 | 3300 | 3800 | 2420 | 2470 | 2530 | 155 | 160 | 160 | 4567 | 4617 | 4884 | 4934 | 5314 | 6/6 |
| | M400 | 4000 | 2850 | 3150 | 3700 | 2620 | 2670 | 2730 | 155 | 160 | 160 | 4647 | 4697 | 4968 | 5018 | 5398 | 6/6 |
| | M425 | 4250 | 2750 | 3050 | 3550 | 2745 | 2795 | 2855 | 155 | 160 | 160 | 4671 | 4721 | 4994 | 5044 | 5424 | 6/6 |
| | M450 | 4500 | 2600 | 2900 | 3400 | 2870 | 2920 | 2980 | 155 | 160 | 160 | 4695 | 4745 | 5021 | 5071 | 5451 | 6/10 |
| | M500 | 5000 | 2700 | 3000 | 3500 | 3120 | 3170 | 3230 | 155 | 160 | 160 | 4743 | 4793 | 5074 | 5124 | 5504 | 6/6 |
| | M550 | 5500 | 2150 | 2450 | 2950 | 3420 | 3470 | 3530 | 155 | 160 | 160 | 4841 | 4891 | 5178 | 5228 | 5608 | 6/6 |
| | M600 | 6000 | 1300 | 1600 | 2100 | 3670 | 3720 | 3780 | 155 | 160 | 160 | 4889 | 4939 | 5231 | 5281 | 5661 | 6/6 |
| 2-stage full free mast | ZM200 | 2000 | 3000 | 3500 | 3800 | 1570 | 1620 | 1680 | 340 | 443 | 503 | 4432 | 4482 | 4728 | 4778 | 5158 | 6/10 |
| | ZM250 | 2500 | 3000 | 3500 | 3800 | 1820 | 1870 | 1930 | 590 | 693 | 753 | 4482 | 4532 | 4781 | 4831 | 5211 | 6/10 |
| | ZM300 | 3000 | 3000 | 3500 | 3800 | 2070 | 2120 | 2180 | 840 | 943 | 1003 | 4532 | 4582 | 4835 | 4885 | 5265 | 6/10 |
| | ZM330 | 3300 | 3000 | 3500 | 3800 | 2220 | 2270 | 2330 | 990 | 1093 | 1153 | 4564 | 4614 | 4868 | 4918 | 5298 | 6/10 |
| | ZM350 | 3500 | 3000 | 3500 | 3800 | 2320 | 2370 | 2430 | 1090 | 1193 | 1253 | 4584 | 4634 | 4889 | 4939 | 5319 | 6/10 |
| | ZM370 | 3700 | 3000 | 3200 | 3800 | 2420 | 2470 | 2530 | 1190 | 1293 | 1353 | 4604 | 4654 | 4910 | 4960 | 5340 | 6/6 |
| | ZM400 | 4000 | 2850 | 3200 | 3700 | 2620 | 2670 | 2730 | 1390 | 1493 | 1553 | 4682 | 4732 | 4990 | 5040 | 5420 | 6/6 |
| | ZM425 | 4250 | 2650 | 2950 | 3450 | 2745 | 2795 | 2855 | 1515 | 1618 | — | 4708 | 4758 | 5017 | 5067 | — | 6/6 |
| | ZM450 | 4500 | 2500 | 2800 | 3300 | 2870 | 2920 | 2980 | 1640 | 1743 | — | 4736 | 4786 | 5046 | 5096 | — | 6/6 |
| | ZM500 | 5000 | 2100 | 2400 | 2900 | 3120 | 3170 | 3230 | 1890 | 1993 | — | 4790 | 4840 | 5102 | 5152 | — | 6/6 |
| | ZM550 | 5500 | 1950 | 2250 | 2750 | 3420 | 3470 | 3530 | 2190 | 2293 | — | 4889 | 4939 | 5205 | 5255 | — | 6/6 |
| | ZM600 | 6000 | 1300 | 1600 | 2100 | 3670 | 3720 | 3780 | 2440 | 2543 | — | 4942 | 4992 | 5261 | 5311 | — | 6/6 |
| 3 stage full free mast | ZSM360 | 3600 | 2850 | 3250 | 3800 | 1870 | 1870 | 1930 | 640 | 640 | 693 | 4643 | 4693 | 4921 | 4971 | 5354 | 6/6 |
| | ZSM400 | 4000 | 2750 | 3100 | 3700 | 2020 | 2020 | 2055 | 790 | 790 | 843 | 4684 | 4734 | 4962 | 5012 | 5395 | 6/6 |
| | ZSM435 | 4350 | 2550 | 2900 | 3400 | 2120 | 2120 | 2180 | 890 | 890 | 943 | 4713 | 4763 | 4991 | 5041 | 5424 | 6/6 |
| | ZSM450 | 4500 | 2450 | 2800 | 3300 | 2170 | 2170 | 2230 | 940 | 940 | 993 | 4728 | 4778 | 5006 | 5056 | 5439 | 6/6 |
| | ZSM470 | 4700 | 2350 | 2700 | 3200 | 2230 | 2230 | 2295 | 1000 | 1000 | 1053 | 4746 | 4796 | 5024 | 5074 | 5457 | 6/6 |
| | ZSM480 | 4800 | 2250 | 2600 | 3100 | 2270 | 2270 | 2330 | 1040 | 1040 | 1093 | 4756 | 4806 | 5034 | 5084 | 5467 | 6/6 |
| | ZSM500 | 5000 | 2100 | 2450 | 2950 | 2370 | 2370 | 2430 | 1140 | 1140 | 1193 | 4783 | 4833 | 5061 | 5111 | 5494 | 6/6 |
| | ZSM540 | 5400 | 1950 | 2300 | 2800 | 2470 | 2470 | 2555 | 1240 | 1240 | 1293 | 4813 | 4863 | 5091 | 5141 | 5524 | 6/6 |
| | ZSM600 | 6000 | 1350 | 1700 | 2200 | 2670 | 2670 | 2780 | 1440 | 1440 | 1493 | 4917 | 4967 | 5103 | 5153 | 5628 | 6/6 |
| | ZSM650 | 6500 | 950 | 1300 | 1800 | 2870 | 2870 | — | 1640 | 1640 | — | 4972 | 5022 | 5250 | 5300 | — | 6/6 |
| | ZSM700 | 7000 | 1800 | 2200 | — | 3045 | 3045 | — | 1815 | 1815 | — | 5022 | 5072 | 5300 | 5350 | — | 6/6 |

Note: *Indicates the rated load capacity of the front wheel with twin tyres; When the front wheels of 3-3.5t are twin tyres (pneumatic tyres) and twin tyres (solid tyres), the service weight is increased by 140kg and 208kg respectively according to the table data; When the front wheels of 3.8t are twin tyres (pneumatic tyres) and twin tyres (solid tyres), the service weight is increased by 103kg and 251kg respectively according to the table data
 2-stage full free mast:3t: When there is no backrest, the free lifting height increases by 477mm; 3.5t-3.8t: When there is no backrest, the free lifting height increases by 407mm.
 3-stage full free mast:3t: When there is no backrest, the free lifting height increases by 427mm; 3.5-3.8t: When there is no backrest, the free lifting height increases by 407mm.

| Optional item | Model | S |
|---|--|---|
| Basic items | Pneumatic tyre* | ● |
| | Solid tyre | ○ |
| | Single tyre (front wheel) | ● |
| | Twin tyre (front wheel)** | ○ |
| | Two piece valve | ● |
| | Three or four piece valve | ○ |
| | Basic type: 3M lifting height mast | ● |
| | Other type and other height seriesmast*** | ○ |
| | Standard series fork | ● |
| | Non standard series forks and attachments | ○ |
| | Standard exterior color (blue grey + Heli red) | ● |
| | Other exterior colors (customized) | ○ |
| Safety items | Turning speed limit | ○ |
| | Reversing armrest with horn switch | ○ |
| | Overspeed 5km / h alarm | ○ |
| | Overspeed 8km / h alarm | ○ |
| | Overspeed 10km / h alarm | ○ |
| | Travelling + lifting + tilting + equipped with OPS function (without lowering) | ● |
| | Full set of OPS functions | ○ |
| | Seat belt switch | ○ |
| | Multi way valve overload | ● |
| | Dry powder fire extinguisher (0.5kg) | ○ |
| | Dry powder fire extinguisher (2kg) | ○ |
| | Carbon dioxide fire extinguisher (2kg) | ○ |
| Comfort items | Reversing buzzer | ● |
| | Reversing Chinese speaker | ○ |
| | No universal key | ● |
| | With universal key | ○ |
| | Electronic lifting upper buffer | ○ |
| | Central wide-angle rearview mirror | ● |
| | Both side rear-view mirrors + center wide-angle rear-view mirror | ○ |
| | Reversing radar (4 probes) | ○ |
| | Reversing image (1 Camera + 4 radar probes) | ○ |
| | Semi enclosed seat | ● |
| | Fully suspended seat | ○ |
| | Instrument panel with 1 USB interface (5V / 1A) | ○ |
| Steering wheel starts steering | ○ | |
| Synchronous steering | ○ | |
| Steering wheel with handle ball | ● | |
| Steering wheel without handle ball | ○ | |
| Cab / Windshield / Air conditioner / Heater | Electric fan | ○ |
| | panel mounted cab (including fan + wiper) | ○ |
| | Heater | ○ |
| | Single cooling air conditioner | ○ |
| | Single cooling air conditioner + heater | ○ |
| | Front windshield (including wiper) | ○ |
| Non standard overhead guard | Rear windshield | ○ |
| | Top windshield (excluding fan) | ○ |
| | 50mm increased of overhead guard height | ○ |
| | 50mm reduced of overhead guard height | ○ |
| Lights | Overhead guard (with protective net) | ○ |
| | LED rear work light (1) | ○ |
| | Rear LED red / Blue spotlight (1) | ○ |
| | Rear and lateral red / blue bar lights | ○ |
| | Fixed LED flashing warning light | ○ |
| | Fixed LED rotary warning lamp | ○ |
| | Fixed LED rotary buzzer warning light | ○ |
| Others | Metric thread | ● |
| | Tilt cylinder jacket | ○ |
| | Steering cylinder jacket | ○ |
| | REMA 320 charging port | ● |
| | Onboard charger | ○ |
| FICS standard type (for China) | ○ | |

Note: *Standard ; "O"Optional ;
 Some non-standard options need to be customized. Please consult local sales personnel or product development technicians before purchasing.
 **3-3.8t rear wheel is equipped with solid tyre as standard.
 ***The small 2t truck is not equipped with twin tyres.
 ***There are restrictions on the type and height of small 2t and 3.8t mast. See the table of mast parameters for details.