

# MC50/MC75

COMPACT TRACK LOADER

Service leads users, Quality drives the future



# MAXBULL



What is a Maxbull compact track loader used for?



## MAIN SPECIFICATIONS

型号	Model		MC50	MC75
额定载重	Rated load capacity	(kg)	700	1000
铲斗容积	Bucket capacity	(m <sup>3</sup> )	0.3	0.5
倾翻载荷	Tipping load	(kg)	1400	2000
提升力	Lifting force	(kg)	1950	1950
工作流量	Hydraulic pump flow	(L/min)	40	75
发动机型号&功率	Engine model & power	(HP)	Xinchai C490 engine (50hp)	Xinchai A498BZG engine (75hp)
操作重量	Operating weight	(kg)	2800	3800
最大行驶速度	Max. travel speed	(km/h)	8.0	12
最大爬坡度	Grade ability	(°)	20	20
履带宽度	Track width	(mm)	300	300
履带接地长度	Length of track on ground	(mm)	1240	1500
油箱容积 (燃油/液压油)	Refill capacity (Fuel tank / Hydraulic tank)		50 / 50	80 / 80

## DIMENSIONS

最大操作高度	Height at Max. extension	A (mm)	3350	3480
铰接销高度	Hinge pin height	B (mm)	2770	2900
总高度 (至驾驶室顶部)	Overall height	C (mm)	2050	2150
带斗总长度	Overall length (with bucket)	D (mm)	2950	3500
无斗总长度	Overall length (without bucket)	E (mm)	2300	2750
带斗宽度	Overall width (with bucket)	F (mm)	1402	1782
轮距	Track width	G (mm)	1102	1462
轴距	Wheel base	H (mm)	1240	1500
离地间隙	Ground clearance	J (mm)	140	200
倾倒角度	Dumping angle	K (°)	40	40
最大卸载高度	Max. dumping height	L (mm)	2100	2230
卸载距离	Reach @ max. dumping height	M (mm)	790	715

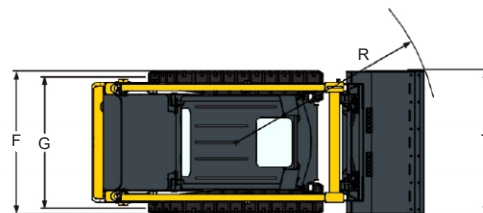
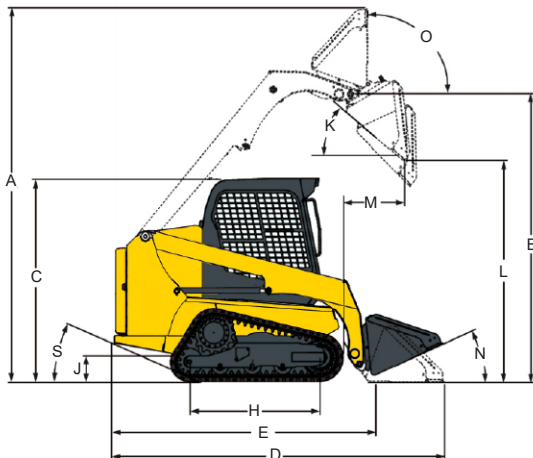

### Anhui Maxbull Machinery Technology Co., Ltd.

ADD: No.2628 Hubei Road, Baohe District, Hefei, Anhui, China.

Tel: 0086 551 63852627

Email: info@maxbull.cn

Web: www.ahmaxbull.com

Authorized dealer