

# General Specifications

Process I/O Module Nest  
Process I/O Module



## GS 33G06K40-01E

### ■ GENERAL

The GS covers the hardware requirements of I/O Modules and I/O Module Nests.

### ■ STANDARD SPECIFICATIONS

#### ● I/O Module Nest

Power Supply: 5.0 V DC supplied from Node Interface Unit.

Installation: Node Interface Unit or I/O Expansion Rack

External Dimensions: 125 (W) x 130 (D) x 248 (H) mm

Weight: Max. 2 kg (without I/O Modules)

Models	Model Names
AMN11	Nest for Analog I/O Modules
AMN12	High-Speed Nest for Analog I/O Modules
AMN21	Nest for Relay I/O Modules
AMN31	Nest for Terminal I/O Modules
AMN32	Nest for Connector I/O Modules
AMN33	Nest for Communication Modules

● Installation Restrictions for I/O Module Nest

**Model AMN12 High-Speed Nest for Analog I/O Module Nest**

- Always install in Nest No. 1. (Figures 1, 2, 5)
- Do not install any I/O module nests in any of the nests No. 1 to No. 4. (Figures 1, 2, 5)
- When installing I/O Module Nests other than Model AMN12 with Model AMN12, always install in Nest No.5. (Figures 2, 5)
- For 19" Rack Mountable type, the I/O Expansion Rack is required. (Figure 5)

**Model AMM22T, AMM22TJ**

- Do not install non-AMM22T, AMM22TJ I/O module below AMM22T, AMM22TJ (See Figures 3, 4 and 8) because AMM22T, AMM22TJ is a module for thermocouple entry. If there were a heat source below AMM22T, AMM22TJ, a reference junction compensation error occur.
- If there is another module (heat source) below AMM22T, AMM22TJ when using 19" Rack Mountable Type, a thermal shield must be inserted between AMM22T, AMM22TJ and the heat source (See Figures 6 and 7).

**Cabinet Mountable Type**

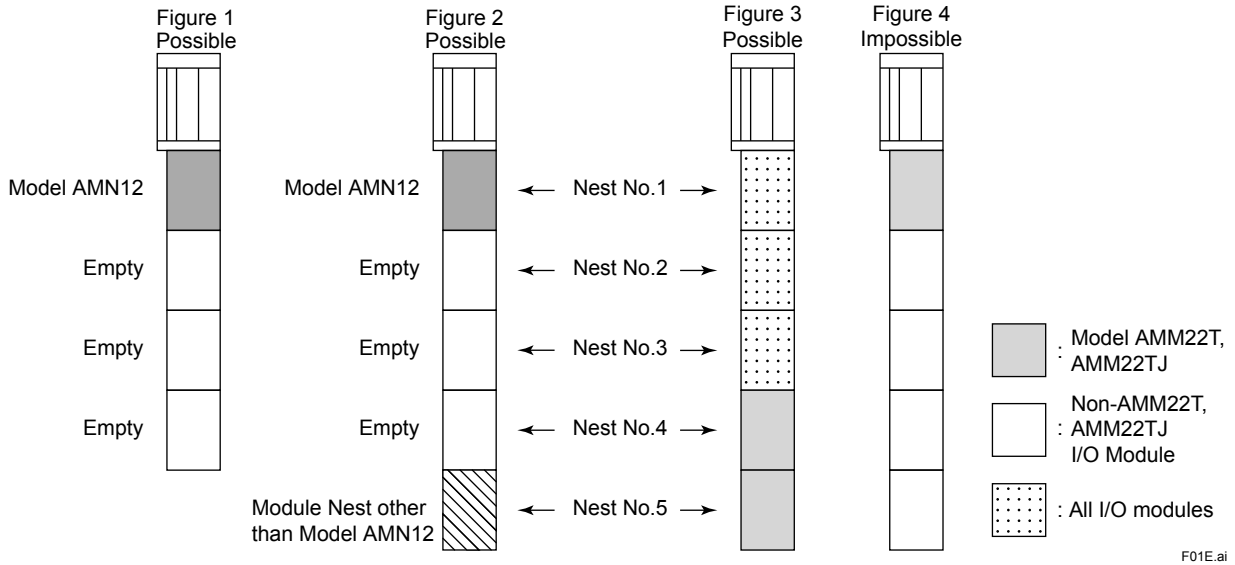

**19" Rack Mountable Type**

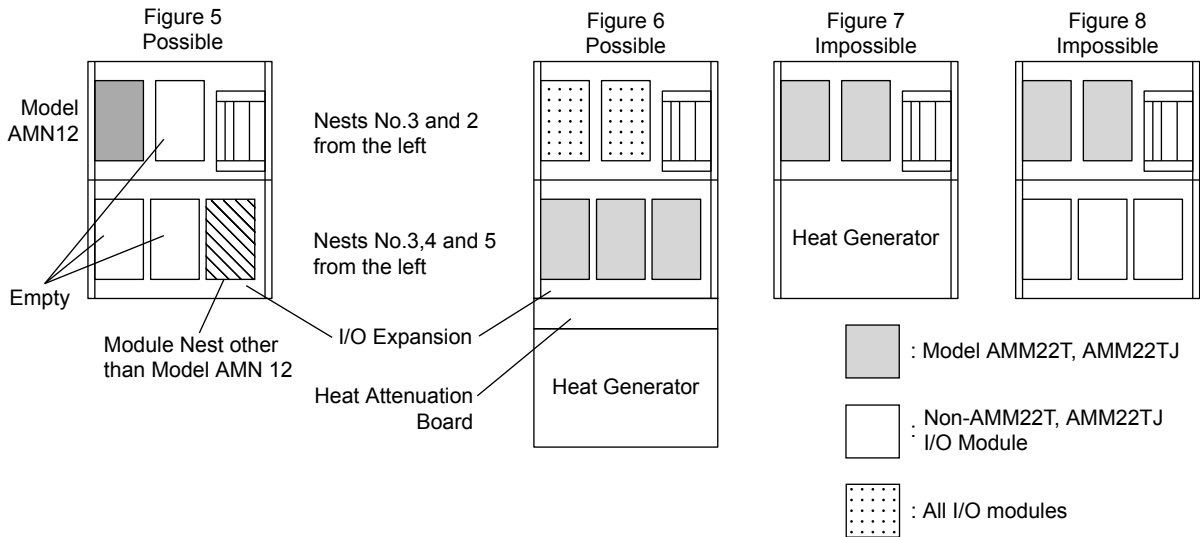

● Type of I/O Modules and Max. No. Installable into the I/O Module Nests

Model	I/O Module Name	I/O Module Nest Model and Max. No. of Modules to be Installed				
		AMN11,12	AMN21	AMN31	AMN32	AMN33
-	<b>Analog I/O Module</b>					
AAM10	Current/Voltage Input Module	Up to 16 modules can be installed	-	-	-	-
AAM11	Current/Voltage Input Module		-	-	-	-
AAM11B	Current/Voltage Input Module (Supports BRAIN)		-	-	-	-
AAM21	mV, Thermocouple, and RTS Input Module		-	-	-	-
AAM21J	mV, Thermocouple, and RTS Input Module (Conforms to IEC584-1995, IEC751-1995)		-	-	-	-
APM11	Pulse Input Module		-	-	-	-
AAM50	Current Output Module		-	-	-	-
AAM51	Current/Voltage Output Module		-	-	-	-
-	<b>Relay I/O Module</b>					
ADM15R	Relay Input Module	-	Only 1	-	-	-
ADM55R	Relay Output Module	-		-	-	-
-	<b>Multiplexer Module (*1)</b>					
AMM12T	Voltage Input Multiplexer Module	-	-	Up to 2	-	-
AMM22M	mV Input Multiplexer Module	-	-		-	-
AMM22T	Thermocouple Input Multiplexer Module	-	-		-	-
AMM22TJ	Thermocouple Input Multiplexer Module (Conforms to IEC584-1995)	-	-		-	-
AMM32T	RTS Input Multiplexer Module	-	-	1	-	-
AMM32TJ	RTS Input Multiplexer Module (Conforms to IEC751-1995)	-	-	1	-	-
AMM42T	2-Wire Transmitter Input Multiplexer Module	-	-	1	-	-
AMM52T	Output Multiplexer Module	-	-	1	-	-
-	<b>Digital I/O Module (*1)</b>					
ADM11T	Contact Input Module (16 Points, Terminal Type)	-	-	Up to 2 (*2)	-	-
ADM12T	Contact Input Module (32 Points, Terminal Type)	-	-		-	-
ADM51T	Contact Output Module (16 Points, Terminal Type)	-	-		-	-
ADM52T	Contact Output Module (32 Points, Terminal Type)	-	-		-	-
ADM11C	Contact Input Module (16 Points, Connector Type)	-	-	-	Up to 4 (*3)	-
ADM12C	Contact Input Module (32 Points, Connector Type)	-	-	-		-
ADM51C	Contact Output Module (16 Points, Connector Type)	-	-	-		-
ADM52C	Contact Output Module (32 Points, Connector Type)	-	-	-		-
-	<b>Communication Module</b>					
ACM11	RS-232C Communication Module	-	-	-	-	Up to 2 (*4)
ACM12	RS-422 / RS-485 Communication Module	-	-	-	-	
ACF11	Fieldbus Communication Module	-	-	-	-	Up to 2 (*5)

- \*1: The Multiplexer Module and Digital I/O Module cannot be installed in the same I/O Module Nest.
- \*2: When the operation mode of Model ADM52T is time-proportioning ON/OFF, only one module can be installed in Slot 1 (see table below).
- \*3: The table below shows installation restrictions by operation mode (No modules can be installed in Slots marked N/A).  
 When the operation mode of ADM51C is time-proportioning ON/OFF, two modules can be installed in Slots 1 and 3.  
 However, when installing one module only, a general ADM□□C can be installed in Slots 3 and 4.  
 When the operation mode of ADM52C is pulse-width-output, two modules can be installed in Slots 1 and 3. However, when installing one module only, a general ADM□□C can be installed in Slots 3 and 4.  
 When the operation mode of ADM52C is time-proportioning ON/OFF, only one module can be installed in Slot 1.
- \*4: These modules cannot be combined with ACF11. ACM11 can be combined with ACM12.
- \*5: This module cannot be combined with ACM11/ACM12.

Models	Functions	AMN32				AMN31	
		Slot 1	Slot 2	Slot 3	Slot 4	Slot 1	Slot 2
ADM52T	Time -proportioning ON/OFF output	-	-	-	-	○	N/A
ADM51C	Time -proportioning ON/OFF output	○	N/A	○	N/A	-	-
ADM52C	One-shot pulse -width -output	○	N/A	○	N/A	-	-
	Time -proportioning ON/OFF output	○	N/A	N/A	N/A	-	-

● Protection of RIO Module Vacant Slots

When I/O modules are not installed, dummy covers should be provided for the backboard connectors to protect them against corrosion.

T9081EF: Dummy frame for AMN1□ Nest (Analog I/O Module )

T9081FB: Dummy frame for RJC (AMN1□ Nest )

T9081CV (\*1): Dummy plate for AMN3□ Nest (Digital I/O Module, Multiplexer Module, etc.)

\*1: The width of T9081CV is same as that of Multiplexer Module (Connector Type) or Digital I/O module (Connector type). So, in some cases, two T9081CV are required for one vacant slot.

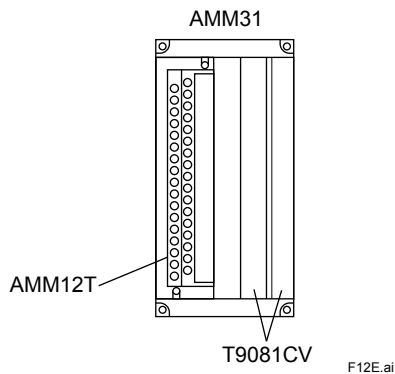

## ● Analog I/O Module

### Current/Voltage Input Modules

These modules receive 4-20 mA from 2-wire transmitters and 1-5 V standardized signals. The modules, covering a wide range of input signals, can also receive signals out of the range of the standardized signals. The modules can be combined with a transmitter with BRAIN Communication, by which communication between the Information and Command Station (ICS) and the transmitter is possible.

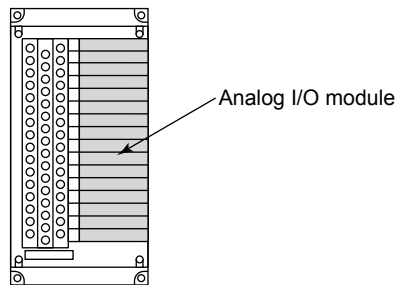

F03E.ai

Items	Item Specifications	
Models	AAM11, AAM11B	
Input signal	0 to 10 V DC	0 to 20 mA DC (*1) (*2) (Supplying power to transmitter is possible)
Input resistance	1 M $\Omega$ (100 k $\Omega$ at power-down)	250 $\Omega$
Allowable input voltage/current	-10 to 30 V DC	40 mA DC or less
Transmitter power supply	-	25.0 to 25.5 V DC (Output current limit: 60 mA DC or less)
Auxiliary voltage output	1 to 5 V DC; Output resistance: 1 $\Omega$ or less; Allowable load resistance: 10 k $\Omega$ or more; Signal grounding is shared with system	
Square root extraction	This function is available by specifying it.	
Accuracy rating	Voltage input: $\pm 4$ mV; Current input: $\pm 16$ $\mu$ A; Auxiliary voltage output: $\pm 12$ mV	
Effect of ambient temperature change	10 $^{\circ}$ C of change: Voltage input: $\pm 4$ mV and $\pm 0.15$ % of indicating value Current input: $\pm 32$ $\mu$ A Auxiliary voltage output: $\pm 24$ mV	
Data update period	50 ms	
Current consumption	300 mA or less (5.0 V DC)	
Signal insulation	Input signals are insulated between systems Withstanding voltage: 1500 V AC/min	
How to install	Install in the I/O Module Nest	
Wiring	Connect to the terminal of the I/O Module Nest with M4 screws	
Setting of input signal specifications	Input signal and its ranges are set with software.	

\*1: These modules can be combined with MTL barrier 728. At this time, wiring resistance must be 10  $\Omega$  or less and the lowest operating voltage of the 2-wire transmitter must be 12 V DC or less.

\*2: When the power of Models AAM11 or AAM11B is OFF or an abnormal condition occurs, the current input loop is open. Do not share current signals with other receivers. To share them, attach Shunt Resistance (250  $\Omega$ ) to the module and use it in the voltage mode.

**Current/Voltage Input Module (Simplified Type)**

This module receives 4-20 mA from 2-wire transmitters and 1-5 V standardized signals.

Items	Item Specifications	
Models	AAM10	
Input signal	1 to 5 V DC	4 to 20 mA DC (*1) (*2) (Supplying power to transmitter is possible)
Input resistance	1 M $\Omega$ (100 k $\Omega$ at power-down)	250 $\Omega$
Allowable input voltage/current	-10 to 30 V DC	40 mA DC or less
Transmitter power supply	-	25.0 to 25.5 V DC (Output current limit: 60 mA DC or less )
Auxiliary voltage output	None	
Square root extraction	None	
Accuracy rating	Voltage input: $\pm 4$ mV; Current input: $\pm 16$ $\mu$ A	
Effect of ambient temperature change	10 $^{\circ}$ C of change: Voltage input: $\pm 8$ mV Current input: $\pm 32$ $\mu$ A Auxiliary voltage output: $\pm 24$ mV	
Data update period	50 ms	
Current consumption	250 mA or less (5.0 V DC)	
Signal insulation	Input signals are insulated between systems Withstanding voltage: 1500 V AC/min	
How to install	Install in the I/O Module Nest	
Wiring	Connect to the terminal of the I/O Module Nest with M4 screws	
Setting of input signal specifications	Input signal and its ranges are set with software	

- \*1: This module can be combined with MTL barrier 728. At this time, wiring resistance must be 10  $\Omega$  or less and the lowest operating voltage of the 2-wire transmitter must be 12 V DC or less.
- \*2: When the power of Model AAM10 is OFF or an abnormal condition occurs, the current input loop is open. Do not share current signals with other receivers. To share them, attach Shunt Resistance (250  $\Omega$  ) to the module and use it in the voltage mode.
- \*3: AAM10 can be used when the whole system's software revision is R2.07 or later.

**Small Electric Power Input Module**

This module receives signals from mV, thermocouple, RTS and potentiometer.

Item	Specifications			
Model	AAM21, AAM21J (*4)			
Input signal	mV	JIS, IEC Standard Thermocouple type K, T, J, E, B (*1), R, S, IEC Standard type N	RTS JIS JPt100 or JIS Pt100 (DIN Pt100) 3-wire type	3-wire potentiometer's total resistance 100 to 2000 Ω
Input range	-50 to 150 mV	-50 to 150 mV	0 to 333 Ω	0 to 30000 Ω (*2)
Allowable input voltage	-0.5 to 4.0 V DC (between terminals B-C)			-
Input resistance	1 MΩ at power-up (3 kΩ at power-down)			-
Accuracy	±20 μV	±20 μV	±0.08 Ω	±0.2 %
Data update period	100 ms			
Signal source resistance	1000 Ω or less		150 Ω or less (wiring resistance per wire)	
RJC input	-	-10 to 70 °C	-	-
RJC accuracy	-	Within ±1 °C (*3)	-	-
Measuring current	-		1 mA	-
Auxiliary voltage output	1 to 5 V DC (Signal ground is shared with system) Output resistance: 1 Ω or less Allowable load resistance: 10 kΩ or more Output range: 0.5 to 5.5 V DC			
Burnout detection	Select from UP/DOWN/OFF (*5)			
Burnout detection time	Within 60 s			
Burnout detection current	0.1 μA (terminal B only) (*5)			
How installed	Installed in AMN11 Nest for Analog I/O Modules			
How connected	Connected to the terminals of the I/O module nest with M4 screws			
Signal isolation	Input signals are isolated between systems. Withstanding voltage: 1500 V AC/min			
Current consumption	150 mA or less (5.0 V DC)			
Input linearization	None	Available	Available	None
Effect of signal source resistance/wiring resistance (burnout is OFF)	1 kΩ of signal source resistance: Input conversion ±20 μV or less		Wiring resistance 10 Ω for terminals A and C: Input conversion ±40 mΩ or less (Wiring of terminals A and C must have the same resistance)	-
Effect of ambient temperature change	For 10 °C change:	mV input: ±40 μV Thermocouple input: ±40 μV RTS input: ±0.16 Ω Potentiometer input: ±0.4 % of span Auxiliary voltage output: ±24 mV		
How input signals are specified	Specify input signals and range by software setting.			

- \*1: Type B does not carry out temperature compensation.
- \*2: The input conversion can be guaranteed only if total resistance is within 100 to 2000 Ω, and the span is 50 % or more of the total resistance. Total resistance can be combined up to 30 kΩ.
- \*3: If measured temperature is lower than 0 °C, multiply the above value by the following coefficient (K).

$$K = \frac{\text{Thermoelectric power per degree C at 0 °C}}{\text{Thermoelectric power per degree C at measured temperature}}$$

F04E.ai

- \*4: AAM21J complies with IEC584-1995, IEC751-1995 to use for thermocouple/RTS input.
- \*5: Disable the burnout detection function when using it with a Zener barrier etc. The voltage drop by the measurement impedance and the burnout current may cause an error.

**Option Specifications for Thermocouple**

When using the AAM21/AAM21J for thermocouple input, order the temperature compensation module for each channel.

		Description
<b>Model</b>	AAM21 AAM21J	
<b>Option Code</b>	/RJ	Temperature Compensation Module for Thermocouple Input

**Pulse Input Module**

This module receives contact ON/OFF, voltage pulse and current pulse.

Item	Specifications
Model	APM11
Input signal	2-wire type: Contact ON/OFF, voltage pulse, current pulse (Supplying power from transmitter is possible) 3-wire type: Power supply type voltage pulse
Input frequency	0 to 10 kHz (*1)
Data update period	100 ms
Min. input pulse width	40 $\mu$ s or more
Input signal level	Contact input Relay contact, transistor contact Detecting level open: 100 k $\Omega$ or more closed: 200 $\Omega$ or less Contact capacity : 15 V DC, 15 mA or more (at 12 V power supply), 30 V DC, 30 mA or more (at 24 V power supply) Voltage/current pulse input (for current input, the value below is the voltage conversion value) VH (high level) +3 to +24 V DC VL (low level) -1 to +8 V DC Swing VH-VL $\geq$ 3V Signal source resistance 1 k $\Omega$ or less
Shunt resistance	Selected from 200/510/1000 $\Omega$ /OFF
Pull-up resistance	68 k $\Omega$ (12 V or 24 V)
Transmitter power supply	12 V DC $\pm$ 10 % 35 mA or less / 24 V DC $\pm$ 10 % 24 mA or less (Output current limit: 40 mA DC or less)
Auxiliary output signal	Output signal: Transistor contact (Open collector); Output contact capacity: 30 V DC, 30 mA or less Signal grounding is shared with the system.
Current consumption	400 mA or less (5.0 V DC)
Signal insulation	Input signals are insulated between systems. Withstanding voltage: 1500 V AC/min
How to install	Install in the I/O Module Nest
Wiring	Connect to the terminal of the I/O Module Nest with M4 screws
Setting of input signal specifications	Input signal and its range are set with software

\*1: Input frequency is 0 to 800 Hz to receive no-voltage contact signals between terminal B and C.



**Current/Voltage Output Module**

This module outputs 4 to 20 mA DC and 0 to 10 V DC.

Item	Specifications	
Model	AAM51	
Output signal	0 to 10 V DC	4 to 20mA DC
Output resistance	1 $\Omega$ or less	500 k $\Omega$ or more
Allowable load resistance	10 k $\Omega$ or more	0 to 750 $\Omega$
Output range	-0.3 to 10.3 V DC	1.0 to 21.5 mA DC
Output voltage limit	-	25.5 V DC or less
Output current limit	60 mA DC or less	-
Output open detection	-	0.65 mA or less
Accuracy rating	Voltage output: $\pm 12$ mV	Current output: $\pm 48$ $\mu$ A
Effect of ambient temperature change	10 $^{\circ}$ C of change: Voltage output $\pm 4$ mV and $\pm 0.15$ % of specified value Current output $\pm 32$ $\mu$ A	
Effect of load resistance change	2 k $\Omega$ load connection: $\pm 4$ mV	0 to 75 $\Omega$ change: $\pm 16$ $\mu$ A
Data update period	20 ms; Step response is 150 ms	
Current consumption	300 mA or less (5.0 V DC)	
Signal insulation	Output signals are insulated between systems. Withstanding voltage: 1500 V AC/min	
How to install	Install in the I/O Module Nest	
Wiring	Connect to the terminal of the I/O Module Nest with M4 screws	
Setting of output signal specifications	Output signal and its range are set with software	

**Current Output Module**

This module outputs 4 to 20 mA DC.

Item	Specifications
Model	AAM50
Output signal	4 to 20mA DC
Output resistance	500 k $\Omega$ or more
Allowable load resistance	0 to 750 $\Omega$
Output range	1.0 to 21.5 mA DC
Output voltage limit	25.5 V DC or less
Output open detection	0.65 mA or less
Accuracy rating	Current output: $\pm 48$ $\mu$ A
Effect of ambient temperature change	10 $^{\circ}$ C of change: Current output $\pm 32$ $\mu$ A
Effect of load resistance change	0 to 75 $\Omega$ of change: $\pm 16$ $\mu$ A
Data update period	20 ms; Step response is 100 ms
Current consumption	250 mA or less (5.0 V DC)
Signal insulation	Output signals are insulated between systems. Withstanding voltage: 1500 V AC/min
How to install	Install in the I/O Module Nest
Wiring	Connect to the terminal of the I/O ModuleNest with M4 screws
Setting of output signal specifications	Output signal and its range are set with software

Note: AAM50 can be used when the whole system's software is R2.07 or later.

● **Relay I/O Modules**

These modules receive or output digital signals from/to the field through relays. They have 16 relay points.

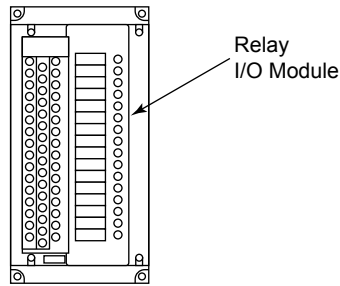

F05E.ai

**Relay Input Module Specifications**

Item	Specifications
Model	ADM15R
Input rating	24 V DC 8.3 mA ±10 % Induction load (*1)
Input format	Non-voltage contact (between A - B) Terminal B side is common with common points
Relay operation time	10 ms or less (*2)
Relay return time	10 ms or less (*2)
Current consumption	2 A or less (5.0 V DC)
Mounting method	Installed in the relay I/O module nest
I/O wiring	Connected to the relay I/O module nest terminal (M4)

\*1: 24 V DC is supplied from the built-in power supply.

\*2: The operation and return time of the relay will be added to the communication process time of the supervisory computer.

**Relay Output Module Specifications**

Item	Specifications
Model	ADM55R
Suffix codes	-1 : Reset action when On-Line maintenance -2 : Hold action when On-Line maintenance (*2)
Output rating	250 V AC 1.5 A or less 125 V DC 0.1 A or less 24 V DC 1.5 A or less
Output format	A contact Between terminals AC B contact Between terminals BC
Relay operation time	10 ms or less (*1)
Relay return time	10 ms or less (*1)
Current consumption	2 A or less (5.0 V DC)
Mounting method	Installed in the relay I/O module nest
I/O wiring	Connected to the relay I/O module nest terminal (M4)

\*1: The operation and return time of the relay will be added to the communication process time of the supervisory computer.

\*2: ADM55R-2 output is held at the status output mode only.

● **Multiplexer Module**

These modules receive up to 16 points from DC voltage, mV, thermocouple and RTS. Measuring inputs can be specified per point.

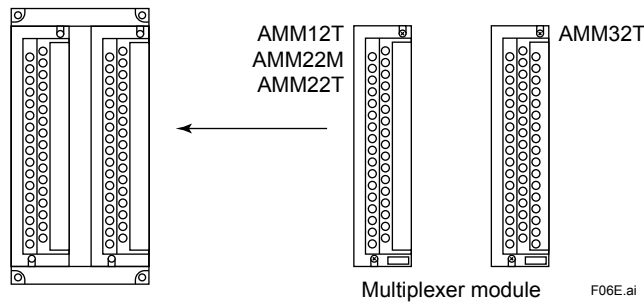

Item	Specifications			
Model	AMM12T	AMM22M	AMM22T, AMM22TJ (*2)	AMM32T, AMM32TJ (*3) (*4)
Input signal	DC voltage	mV	Thermocouple JIS, IEC Standard type K, T, J, E, B, R, S IEC Standard type N	RTS JIS JPt100 or JIS Pt100 (DIN Pt100) 3-wire type
Input range	-10 to 10 V DC	-100 to 100 mV DC	-100 to 100 mV DC	-200 to 600 °C
Allowable input voltage	-30 to 30 V DC	-0.5 to 4.0 V DC	-0.5 to 4.0 V DC	-
Input resistance	1 MΩ			-
Signal insulation	Input signals are isolated between systems			
Data update period	1 s			
Accuracy	±4 mV	±40 μV	±40 μV	±0.15 Ω
Disconnection detection time	-	10 s Max.		20 s Max.
Disconnection detection current	-	0.1 μA		
Allowable signal source resistance	-	1 kΩ Max.	1 kΩ Max.	-
Allowable wiring resistance		-		150 Ω max. (per wire)
RJC input	-		-10 to 70 °C	-
RJC accuracy	-		±1 °C (*1)	-
Allowable common mode voltage	200 V AC			-
Measuring current		-		1 mA
Burnout detection	-	Select from UP/DOWN/OFF.		
Input parallel connection	Permitted (burnout OFF)		Not permitted	
How installed	Installed in the I/O module nest.			
How connected	Connected to the terminals of the I/O module nest with M4 screws.			
Effect of ambient temperature change	For 10 °C change : DC voltage: ±8 mV or less mV input: ±80 μV or less Thermocouple input: ±80 μV or less RTS Input: ±0.3 Ω or less			
Current consumption	500 mA or less (5.0 V DC)			
How input signals are specified	Specify input signals and range by software setting.			

\*1: If measured temperature is lower than 0 °C, multiply the above value by the following coefficient (K).

$$K = \frac{\text{Thermoelectric power per degree C at 0 °C}}{\text{Thermoelectric power per degree C at measured temperature}}$$

F04E.ai

\*2: Conforms to IEC584-1995.

\*3: Conforms to IEC751-1995.

\*4: Wiring resistance for the signal cables connected to terminal A and terminal B (left) must be identical.

● **2-Wire Transmitter Input/Output Multiplexer Modules**

AMM42T receives up to 16 4-20 mA DC signals from 2-wire transmitter. AMM52T outputs up to 16 4-20 mA DC signals to 2-wire transmitter.

Input/output signals are not insulated between system and field, and between channels.

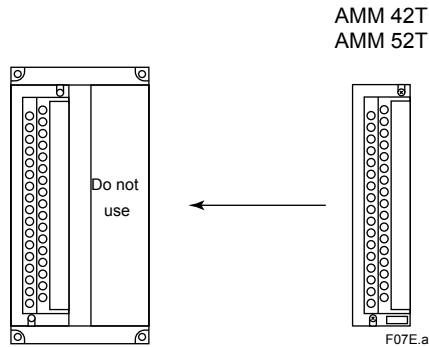

Item	Specifications	
	AMM42T	AMM52T
Model	AMM42T	AMM52T
Input signal	4 to 20 mA DC	-
Output signal	-	4 to 20 mA DC
Allowable input voltage	40 mA or less	-
Transmitter power supply	23.5 to 24.5 V DC (output power limit: 60 mA or less)	-
Input resistance	250 Ω (can be changed to 70 Ω when connected to barrier)	-
Output resistance	-	500 kΩ or more
Allowable load resistance	-	0 to 750 Ω
Output range	-	1.0 to 21.5 mA DC
Output voltage limit	-	25.5 V DC or less
Signal insulation	Non-insulation between system - field, and channels	Non-insulation between system - field, and channels
Data update period	1 s	1 s
Accuracy rating	±16 μA	±48 μA
Current consumption	4 A or less (5.0 V DC)	4 A or less (5.0 V DC)
How to install	Install in the I/O module nest	Install in the I/O module nest
Wiring	Connect to the terminal of the I/O module nest with M4 screw	Connect to the terminal of the I/O module nest with M4 screw
Effect of ambient temperature change	10 °C of change ±32 μA	10 °C of change ±32 μA

Note: Can be combined with MTL Barrier 787S by setting input resistance to 70 Ω. At this time, wiring resistance must be 10 Ω or less and the minimum operating voltage of 2-wire transmitter must be 12 V DC or less.

● Digital I/O Modules

These modules receive and output 16 or 32 contact I/O points.

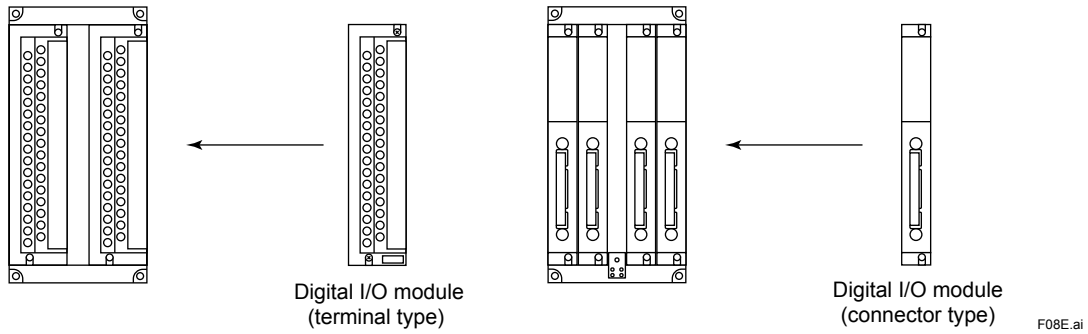

Digital Input Module Specifications

Item	Specifications			
	Terminal type		Connector type	
Type				
Model	ADM11T (*1)	ADM12T (*1)	ADM11C	ADM12C
No. of I/O points	16 points	32 points	16 points	32 points
Input signal	Contact input: OFF signal 100 kΩ or more, ON signal 200 Ω or less Voltage input: OFF signal 4.5 to 25 V DC, ON signal ± 1 V DC, 200 Ω or less			
Contact rating	5 V DC, 20 mA or more (external contact standard)			
Pulse width	40 ms or more			
Pulse period	10 Hz or less			
Current consumption	600 mA or less (5.0 V DC)			
Function Status input Push-button input	Detection function of ON/OFF status Function which counts edge of push-buttons			
Signal insulation	Each point	Common minus side every 16 points	Each point	Common minus side every 16 points
Mounting method	Installed in the I/O module nest			
Signal connection	Connection to the I/O module nest terminal (M4 screw)		KS2 or KS3 cable	KS9 or KS10 cable

\*1: Specify the option code "/CE1" to comply with the EMC Standards.

**Digital Output Module Specifications**

Item	Specifications			
	Terminal type		Connector type	
Type				
Model	ADM51T (*1)	ADM52T (*1)	ADM51C	ADM52C
Suffix codes	-1:Reset action when On-line maintenance -2:Hold action when On-line maintenance (*2)			
No. of I/O points	16 points	32 points	16 points	32 points
Output signal	Transistor contact			
Contact rating	Resistive load/Inductive load: 30 V DC, 100 mA or less			
Pulse width	0.1 to 7200 s: Setting at time of pulse-type, pulse width mode			
Pulse width resolution	20 ms			
Current consumption	600 mA or less (5.0 V DC)			
Function Status output Pulse type output Pulse width output Time proportional ON/OFF	Output function of ON/OFF status Pulse output function of status One-shot pulse width output function ON/OFF of time proportion			
Signal insulation	Each point	Common minus side every 16 points	Each point	Common minus side every 16 points
Mounting method	Installed in the I/O module nest			
Signal connection	Connection to the I/O module nest terminal (M4 screw)		KS2 or KS3 cable	KS9 or KS10 cable
CPU halt status/ Communication bus termination status	Detection time or output mode can be set when selecting the abnormal detection mode			

\*1: Specify the option code "/CE1" to comply with the EMC Standards.

\*2: ADM51T-2, ADM52T-2, ADM51C-2, ADM52C-2 outputs are held at the status output mode only.

● **Communication Module**

With subsystem communication packages, these modules send/receive data to/from subsystems such as PLCs, via serial communication circuits.

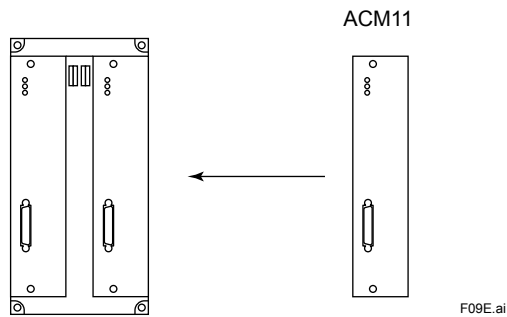

Item	Specifications	
	ACM11	ACM12
Model	ACM11	ACM12
Interface	RS-232C (1 port)	RS-422 or RS-485 (1 port)
How connected	Point-to-point	Point-to-point, Multipoint
How communicates	Half-duplex	
How synchronizes	Start-stop synchronization	
Communication speed	1200/2400/4800/9600/19200 bps	
Transmission code	ASCII/binary	
Character length	7/8 bit	
Stop bit length	1/2 bit	
Parity check	None/odd/even (Note: "No parity" cannot be specified at 19200 bps.)	
When a signal is received after data transmission	1 ms (standard); immediately (in special case)	1 ms
Transmission distance	Max. 15 m	Max. 1200 m (Total length)
How installed	Installed in the Communication Module Nest (These modules cannot be combined with ACF11. ACM11 can be combined with ACM12.)	
Wiring	KB3, AKB141, AKB143 (RS-232C modem) KB4, AKB142, AKB144 (RS-232C null-modem) cable	3 pairs shielded cable or AKB161 (cable to connect ACM12 with FA500; Max. 100 m)
How connected	Dsub 25 pin (female)	Connected to the terminal (6 poles) with M4 screws.
Current consumption	1 A (5.0 V DC)	

● **Fieldbus Communication Module**

A Fieldbus Communication Module sends/receives data to/from field devices on a fieldbus.

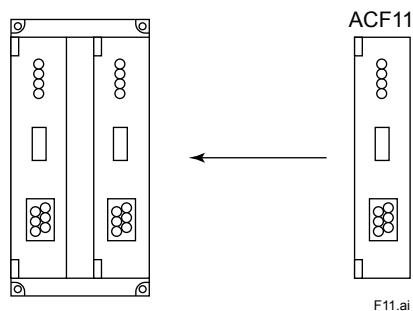

Item	Specifications
Model	ACF11
Interface	FOUNDATION™ fieldbus (Low Speed Voltage Mode)
Communication speed	31.25 kbps
Function	LAS function, Network power supply function
No. of field devices connected	Up to 32 devices per ACF11 (incl. ACF11)
Network power supply specifications	Output voltage: 18-20 V DC Continuous output current: 80 mA or less Transient output current: 100 mA or less (20 ms or less) Output ON/OFF: Specify in the card (When using external power supply, the output is OFF.)
Current consumption	1.4 A or less (5.0 V DC)
Signal isolation	Signals are isolated between system and field. Withstanding voltage: 1500 V AC/min
Bus connection	Connect two terminals with M4 screws. Terminal: detachable Compliant terminator: YCB138
How installed	Installed in the Communication Module Nest (This module cannot be combined with ACM11/12)



● **NI-compliant I/O Modules and Their Parameters**

I/O modules are compliant with Non-Incendive (NI) rule of CSA Standards. This means that I/O modules can be installed in Class I, Division 2 hazardous area by installing ANS50/AND50 Node Unit with I/O modules in a cabinet approved by CSA or local explosion-proof auditor; and directly connected with NI-compliant local devices installed in hazardous area.

**Compliance**

- Class I, Division 2, Groups A, B, C and D T4
- CSA Standard C22.2-No.157-92
- CSA Standard C22.2-No.213-M1987
- ISA Standard ISA S12.12 1994

**I/O Modules and Parameters**

For parameters and connectivity, see "Installation Guidance" (TI 33Q01J10-01E).

■ **EXTERNAL DIMENSIONS OF THE I/O MODULE NEST**

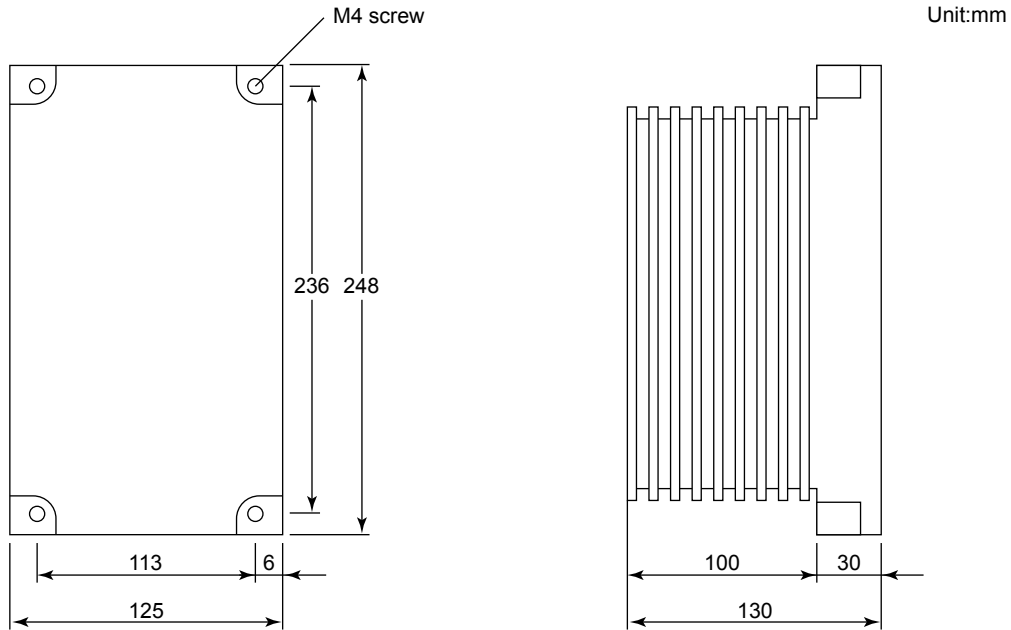

F10E.ai

■ **TRADEMARK**

- The word "FOUNDATION" of FOUNDATION fieldbus is a trademark of Fieldbus Foundation.
- CENTUM is registered trademark of Yokogawa Electric Corporation.