

CONTENTS

1. INTRODUCTION.....	2
2. MAIN FEATURES	2
3. FRONT PANEL DESCRIPTION.....	2
4. PROGRAMMING WINDING PARAMETER.....	4
5. WINDING METHOD DESCRIPTION	6
6. WINDING EXECUTION	8
7. CONFIGURATION SETTING.....	9
8. INSTALLATION AND WIRING.....	11
9. MAINTAIN AND TROUBLESHOOTING	13

1. INTRODUCTION

CNC-200A is a series of COIL WINDING MACHINE CONTROLLER developed by **MINSU AUTOMATION**. It not only retains all the features of previous designs, it also has a low noise level and is less sensitive to external power fluctuation.

CNC-200A also features an integrated design: putting stepper motor driver, DC motor speed controller, brake and power supplier control circuits into one control box, simultaneously achieving size reduction, high performance and low cost.

2. MAIN FEATURES

- ◆ **Single chip Microprocessor design, has further higher performance and higher functions; it also has less sensitive to external power fluctuation or to external electromagnetic interference.**
- ◆ **Memory use FLASH ROM, capacity capable storing up to 1000 steps winding data, 9 winding parameters, and 5 options can be independently assigned for each step. Off-power memory retention without battery.**
- ◆ **Winding speed can be specified using the front panel keypad, resulting in easy programming of multi-step, multi-speed settings.**
- ◆ **Guiding traverse shaft stepper motor with a constant-current driver offering fast wire guiding speeds.**
- ◆ **Guiding traverse shaft offering 10 steps moving speed selection.**
- ◆ **Software can be update through the personal computer.**
- ◆ **Power input AC100V~120V 、 220V~240V 600VA(max).**



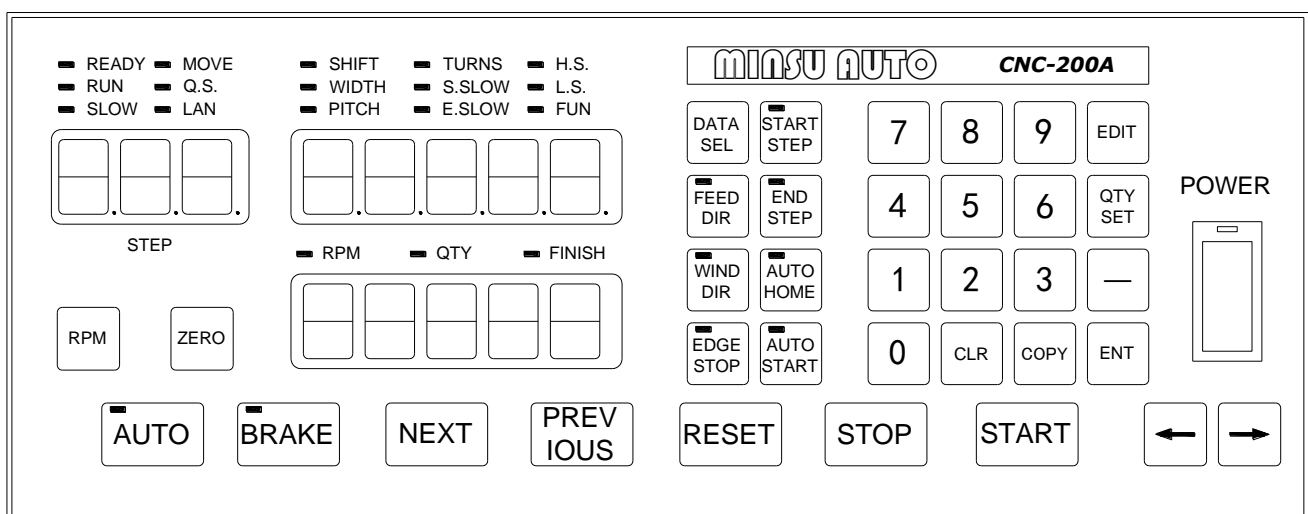





















3. FRONT PANEL DESCRIPTION



3.1. Power switch

Power supplier equipped, controls the AC power to the controller.

3.2. Key pads

-  ~  : 10 key, for entering numerical values.
-  : Enter into EDIT mode.
-  : Specify target production quantity.
-  : Specify starting step in memory.
-  : Specify ending step in memory.
-  : Select item of parameter during edit , or to switch display mode during running.
-  : Select guiding direction for each step during edit.
-  : Select winding direction for each step during edit.
-  : To specify whether to suspend winding, during the guiding traverse moving to the edges of the width.
-  : Select whether to have auto-positioning function for each step.
-  : Select whether to have auto-starting function for each step.
-  : Reduce step number by one, or reduce production counter by one.
-  : During programming, clear current data to zero.
-  : Copy the data of previous step into current step.
-  : Write data into memory.
-  : Switch display to shows between production counter and speed (RPM).
-  : Hold down this key for two seconds to reset production counter.
-  : Switch between automatic and manual mode.
-  : Switch the brake between lock and unlock during motor stop.
-  : Skip current step and go to the next step.
-  : Discard current step and go to the previous step
-  : At any time, discontinues current operation and return to ready mode.
-  : Pause during winding.
-  : Restart during pause, or pause during winding.

3.3. Digital display

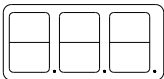

STEP DISPLAY: Show the current step number being wound or being programmed.

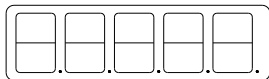

DATA DISPLAY: During programming, in combination with LED, shows the parameter being programmed. During winding or ready mode, show the current number of turns or show the guiding traverse shafts position.

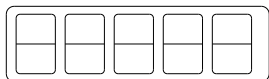

COUNTER DISPLAY: Shows production counter or RPM.

3.4. Status indicators

- READY** : Lit means in READY mode, flash means PAUSE mode, Not lit means winding or programming in progress.
- RUN** : Lit means winding in progress; not lit means not in progress.
- SLOW** : During winding, lit means low speed winding; not lit means high speed winding.
- MOVE** : Lit means guiding traverse is fixing the starting position for winding or is returning to the home position.
- CUT** : Lit means wire break, stop winding.
- FINISH**: Will lit when reaching the preset production counter display count.
- RPM** : Lit means the counter display shows RPM.
- QTY** : Lit means the counter display shows production counter.

3.5. Winding parameters definitions

- SHIFT** : Start position of the guiding traverse.
[Setting range 0.00~ 999.99 mm].
- WIDTH** : Guiding region of the guiding traverse . [Setting range 0 ~999.99 mm].
- PITCH** : Diameter of the copper wire. [Setting range 0~ 9.999mm].
- URNS** : Total number of turns to be wound.
[Setting range 0.0~9999.9 or 0~99999 turns].
- S.SLOW** : Number of turns to be wound at low speed, when start winding.
[Setting range 0~999.9 turns].
- E.SLOW** : Number of turns to be done at low speed prior to stopping.
[Setting range 0~999.9 turns].
- H.S.** : High winding speed. [Setting range from 0~99%].
- L.S.** : Low winding speed. [Setting range from 0~25%].
- FUN** : Winding complete output signal setting.

4. PROGRAMMING WINGING PARAMETER

4.1. MEMORY RANGE SELECTION

CNC-200A contains 1000 memory step, by defining the region, users can effectively manage the memory. Various winding parameter can be stored in different regions and can be retrieved instantaneously. After specifying the regions, programming and winding can be done in those regions; all un-selected regions will retain their original contents and unmodified. When setting the STEP number, the Ending step number must be larger than the Starting step number, or the winding operation will not start

◆ Specifying starting step

In ready mode, press to selected. [Setting range 0 ~ 999].

◆ Specifying ending step

In ready mode, press to selected. [Setting range 0 ~ 999].

4.2. Programming winding parameter

In READY mode, press invokes the programming mode, the STEP DISPLAY shows START STEP, the parameter indicator 『SHIFT』 lit, the DATA DISPLAY shows SHIFT setting value, the SHIFT can be changed by pressing the numerical keys followed by the key.

After that the STEP number will automatically increase by one, to continue set the SHIFT for next step. When the STEP number is larger than the END STEP, the STEP number will restore to the START STEP and the indicator light will change from 『SHIFT』 to 『WIDTH』 to specifying the width for each STEP. Repeat the same procedure using numerical keys and the key, all winding parameters for each STEP can thus be programmed, after that press key again to go back to ready mode.

The following functions are also available:

- : To select guiding direction, forward or reverse.
- : To select winding direction, clockwise or counter-clockwise.
- : To specify whether to suspend winding when the guiding traverse moves to the two edges of the width.
- : To select whether guiding traverse move to the starting position automatically or upon a manual pressing of the key.
- : Select whether to have auto-starting function for each step.
- : Clear the setting value .
- : Copy the content of the previous step to the current step.
- : Go back to the previous step.
- : To scroll through different parameters.

Each time when change the parameters and selections, key must be pressed to effect the change.

4.3. Guiding traverse shaft introduce setting

During set the 『SHIFT』, 『WIDTH』 and 『guiding traverse travel limit』, can use numeric keypad to set location data or can also use , or , keys to leading the guiding traverse shaft location.

4.4. Clear all winding parameter

In the READY mode, press will clear all the winding parameter in the memory. Be cautious in using this function or all the data will be lost.

5. WINDING METHOD DESCRIPTION

Prior to winding, the general winding principles are explained below so the operators can have a better understanding of the performance of the controller and make better use of it.

5.1. Turns counting mode

◆ Absolute counting mode

Winding spindle shaft is capable of fixed-point stopping. Upon each restart, the turn count will reset only the integer portion of the turn's to zero, with the decimal unchanged. For example, for a previous number of 100.3 turns, when restarting the next step winding, the counting will start with 0.3 to avoid accumulation of spindle shaft free play error from consecutive windings. This counting method may cause insufficient winding by one turn. Therefore, when starting from **0.9**, the spindle will turn to the **0.0** before it starts counting.

◆ Relative counting mode

This counting method zeros the counter upon each restart, therefore it is easy to understand and will not cause insufficient winding.

5.2. Special Wire-guiding mode

◆ Interlace wire-guiding

If the 『WIDTH』 of the step is zero, the wire-guiding becomes interlace mode. When it begins winding, the wire-guiding will follow the wire direction to proceed two wire diameters and regress one wire diameters cyclically until the step of winding ends. This mode especially suits the inductor winding.

◆ Non wire-guiding

Sometimes, the winding device may be used to winding adhesive tapes or copper foil. When the wire-guiding is not needed, 『PITCH』 may be adjusted to zero and the wire-guiding won't be move.

5.3. Start switch operation mode

◆ ON-OFF mode

Press down start switch to start winding and release start switch to stop winding immediately.

◆ Trigger mode

Press and release start switch once to start winding, press and release start switch again to stop winding

5.4. Running mode





◆ Continual mode

Before it begins winding, if 『SHIFT』 of the step set as 999.99, then the starting position, the width, the wire-guiding direction and the winding direction won't be re-read. The values are not changed, that is the wire guiding will continue guiding wires on the same position. The width and left-right margins are the same as the ones of the previous section. Both the wire-guiding and winding directions are not changed either. This mode especially suits to winding which have the multiple drawing tops in the same sets of coils.

◆ **Edges slow mode**

The winding speed will slow down before the guiding traverse reach to the two edges of the width (work with 『E.SLOW』 turns). After the guiding traverse veered, then restore to hi-speed winding. (Refer to the section 7.1. edge slow mode).

◆ **Automatically circularly mode**

If  key set to on, it means Automatically circularly mode, in this mode when finish a step of winding it will automatically get into next step and start winding without press  key (work with  and  keys).

5.5. How to set winding turns accurately

◆ **Preset method**

Set the 『E.SLOW』 to zero first and then set the 『TURNS』 to the desired number. Set proper parameters according to copper wire, bobbin, tension, etc, then press  to start winding. When finished, obtain the actual number of turns and calculate the number of overshoot turns. Go into programming mode and subtract the number of the overshoot turns from the 『TURNS』 to obtain the required setting.

This method has a higher throughput, however, the resulting stopping location may not be precise.

◆ **High-Low speed method**

This method uses a combination of 『H.S』/『L.S.』 and 『E.SLOW』 to achieve the desired number of turns.

The 『L.S.』 should not be too high. The number of 『E.SLOW』 turns must be adequate to allow the spindle shaft to slow down to low speed before reaching the total number of turns. This can result in precise stopping location.

◆ **Double-brake method**

As the winding turns of the winding shaft reach the numbers of the 『E.SLOW』, brake for a short period first. After the winding shaft stops, continue winding at low speed.

Therefore the numbers of the slow speed may be reduced and the efficiency of winding may be increased,

(Refer to the section 7.1. braking mode).

6. WINDING EXECUTION

6.1. To start winding

After set up all data items, press **START** key, the winding process begins in accordance with the set-up content. Press **STOP** key to pause winding. During winding, press the **0** key, the winding speed can be switch between high speed and low speed.

The following key functions are available during PAUSE mode:

- PREVIOUS** : Give up the numbers of the winding turns and regress one step.
- NEXT** : Finish current step and proceed to next step.
- START** : Continue winding.
- RESET** : Give up winding and go back to the READY mode.

6.2. Change the display mode

During winding or during PAUSE mode, press **DATA SEL** key, the DATA DISPLAY can be change the display mode between turns or guiding traverse position.

6.3. Winding speed (RPM) display

Pressing **RPM** key will cause the PIECE COUNT DISPLAY to display the spindle shaft RPM without interrupting the counting. Pressing **RPM** again will change the PIECE COUNT DISPLAY back to displaying the piece count.

6.4. Production counter management

Upon turning on the power, the counter display will show the production counter. During wining, each time the winding process goes from the START STEP to the END STEP, the counter will automatically increase by one.

◆ Preset production counter :

In READY mode, press **QTY SET** key once and key in desired values **0~99999** followed by the **ENT** key. During winding when the production counter reaches the preset value, the FINISH led will lit. [Setting range 0~99999].

◆ Decrease production counter :

During READY or PAUSE mode, press the **-** key and hold down for two seconds the piece counter will decrease by one.

◆ Reset production counter :

In any time holding down **ZERO** key for two seconds, it will set the piece counter to zero.

7. CONFIGURATION SETTING

CNC-200A is a multi-purpose design, to meet various requirements; additional settings are configured to provide flexibility for additional applications.

In the READY mode, press the following keys combination as section [7.1. ~7.10], the DATA DISPLAY will show corresponding setting value. If no change is necessary, press the **ENT** key get back to READY mode. Or press **—** key to get into change mode, then the parameter can be changed by pressing the numerical key followed by the **ENT** key.

7.1. Winding mode selection **EDIT DATA SEL** 0 Initial value[10010100]

In this function the STEP display and the DATA display will shows eight digits, representing eight winding mode selections respectively. Press numerical keys as below to set each digit.

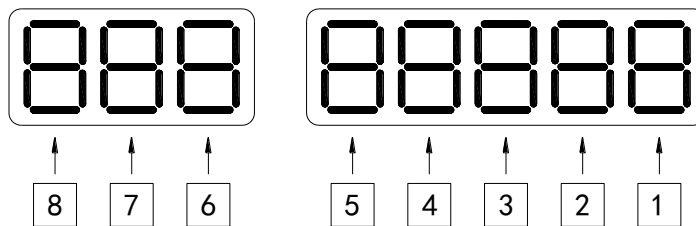

- 1 NO Function**
- 2 Control Mode** : Select control mode of winding spindle driver.
0 represents CW=Forward/Stop, CCW=Reverse/Stop.
1 represents RUN=Motion/stop, DIR=Forward/Reverse,
- 3 Counting mode** : Select the counting mode of the winding spindle shaft.
0 represents with zero point and using absolute counting mode.
1 represents without zero point and using relative counting mode.
2 represents with zero point and using relative counting mode.
3 represents without zero point and using absolute counting mode.
- 4 Edge slow** : Slow down the winding speed before the guiding traverse reach to the two edges of the width.
0 represents not slow down; **1** represents to slow down.
- 5 Braking mode** : Select the braking mode of the winding spindle.
0 represents single brake mode; **1** represents double brake mode.
- 6 Counting unit** : Select 0.1 or 1 turns as your count unit.
0 represents **0.1**(0.0 to 9999.9 turns); **1** represents **1**(0 to 99999 turns).
- 7 Guiding traverse unit** : Select the basic unit of guiding traverse.
0 represents **mm**; **1** represents **inch** (must using lead screw in imperial).
- 8 Operation mode** : Select operation mode for the START switch.
0 represents ON-OFF mode; **1** represents Trigger mode.
 The **START** key on the front panel always as the Trigger mode.

7.2. Station number **EDIT DATA SEL** 1 Initial value[0]

[Setting range 01~99].

7.3. Password EDIT DATA SEL 2 Initial value[0000]

This password is used to protect the setting data in memory. After you set this password, you cannot change any winding parameter and configuration data in normal sequence. You have to key in four numbers of password before press the EDIT, START STEP, END STEP, QTY SET keys. If the password has been passed once, you can change any data in normal sequence until you turn off the power or press RESET key. You must to remember the password or you cannot change any data.

[Setting range 0000~9999]. Set 0000 means no password.

7.4. Travel limit EDIT DATA SEL 3 Initial value[999.99]

Set the maximum travel distance of guiding traverse. During winding when the guiding traverse reaches this position, the motor stop winding immediately, and the DATA DISPLAY shows error message, then RESET and go back to the READY mode. [Setting range 000.00~999.99]. 999.99 Means no limit.

7.5. Fixed location EDIT DATA SEL 4 Initial value[1]

To set how often, must be correct the guiding traverse location. Each time when finish this number of product pieces, the guiding traverse will moves to the home position to correct the location before moving to starting position.[Setting range 00~ 99]. Set 00 means not to do this function.

7.6. Limited winding speed EDIT DATA SEL 5 Initial value[0]

This value is to limited winding speed and make sure the winding spindle shaft and guiding traverse are in synchronization. The controller uses this value to calculate with wire PITCH of current step, and then to limited maximum winding speed of current step. [Setting range 0~ 99999]. Set 0 means no limit speed.

7.7. Brake holding time EDIT DATA SEL 6 Initial value[0.3]

To set the hold times for brake. [Setting range 0.1~9.9 sec].

7.8. Guiding traverse moving speed selection EDIT DATA SEL 7 Initial value[20]

The speed at which the guiding traverse moving to the starting position and returning to the home position. [Setting range 0~99].

7.9. Moving increment EDIT DATA SEL 8 Initial value[2.00]

Guiding traverse moving increment. This value is calculated according to the specification of winding machines.[Setting range 0.01~99.99].

Moving increment = (Screw pitch × Gear ratio ÷ Resolution of guiding motor)

Example : Screw pitch = 5mm 、 Gear ratio = 1.6 、 Resolution of guiding motor = 400

Moving increment = $5 \times 1.6 \div 400 = 0.02\text{mm}$

Setting value = Moving increment × 100 = $0.02 \times 100 = 2.00$

7.10. Acceleration times EDIT DATA SEL 9 Initial value[0]

Set the accelerate times for the winding spindle [Setting range 00~99].

00 means shortest acceleration times ; **99** means longest acceleration times.

$T(\text{ms}) = (\text{H.S.} - \text{L.S.}) \times \left[(N + 1) \times 2 \right]$

7.11. Reset all configuration data EDIT CLR 0 ENT

In READY mode press EDIT CLR 0 ENT keys, it will reset all the configuration data and replace by initial data. Be cautious in use this function.

8. INSTALLATION AND WIRING

- ◆ The controllers should be operated in an environment that is protected from moisture, corrosive gases, or liquid, and free from airborne dust, metallic particles, and magnetic noise.
- ◆ Do not block the intake/exhaust ports of the controller. Otherwise, a fault may occur.
- ◆ Make sure that the power source supplies the correct voltage and is capable of supplying the required current to the controllers.
- ◆ Do not connect or disconnect wires and connectors while power is applied to the controller.
- ◆ Make sure the machine and controllers are properly grounded.
- ◆ Make sure that the leads and connectors are connected correctly.
- ◆ Normally operate under 10°C ~ 40°C environment; over 40°C should perform under good ventilation, avoid heating.

8.1. Wiring diagram for CN2~CN6

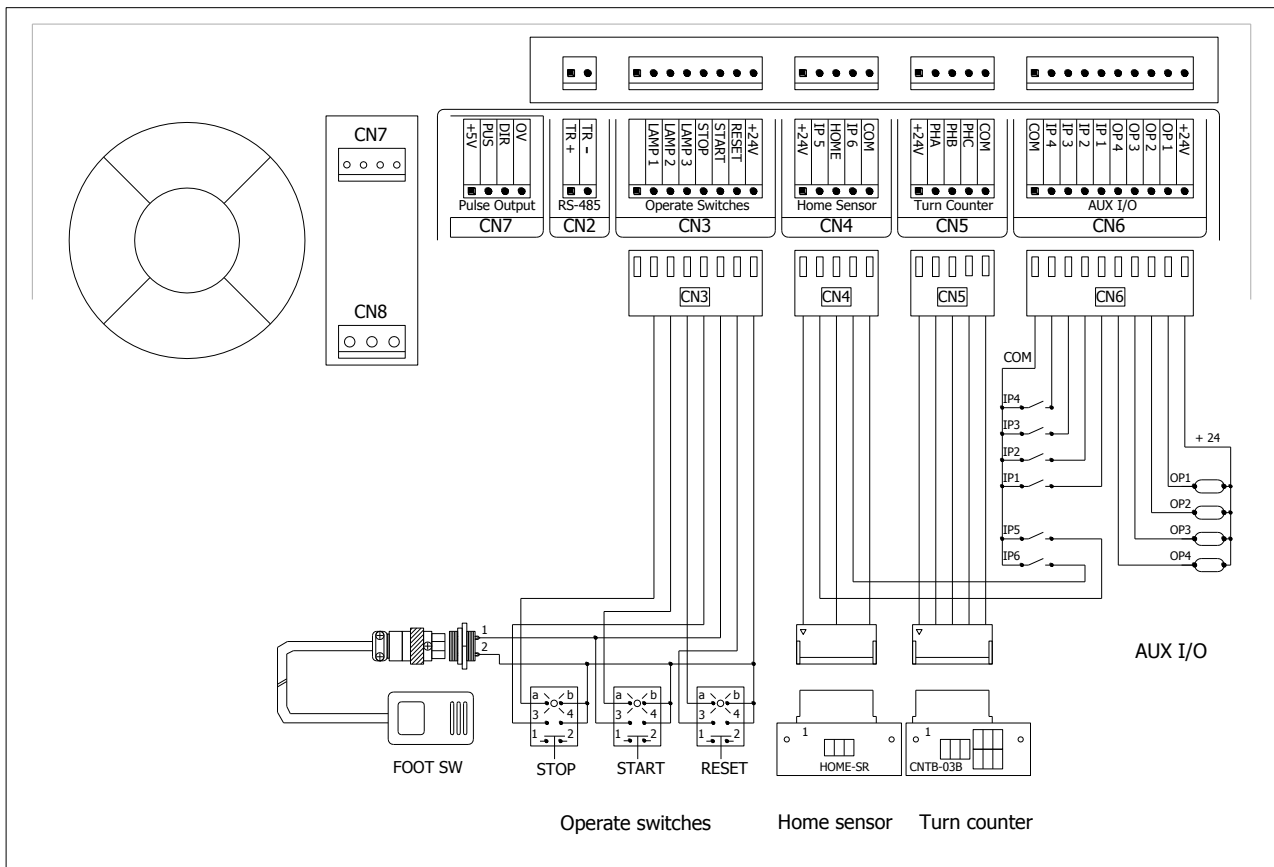

8.4. Wiring diagram

◆ Drive STEP Motor in directly

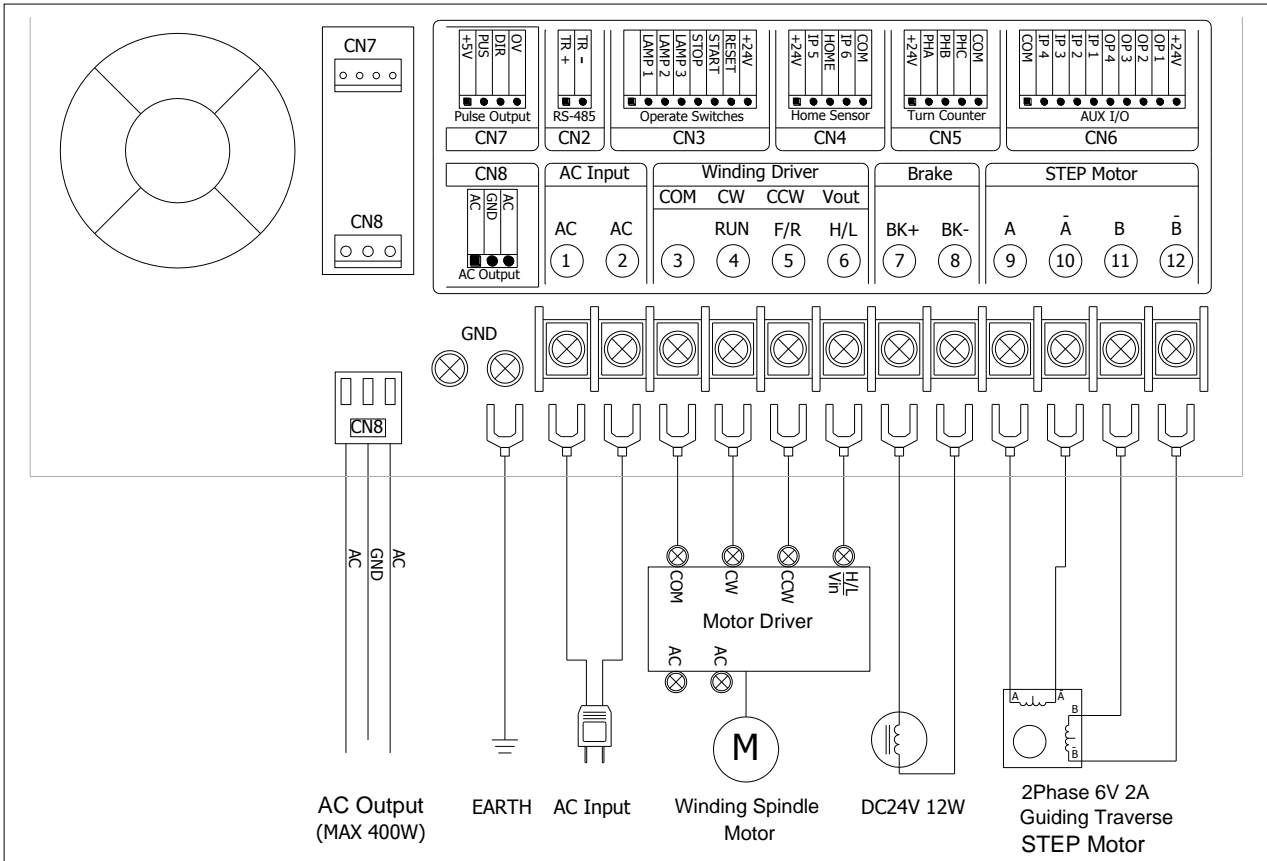

◆ External connect STEP Motor driver

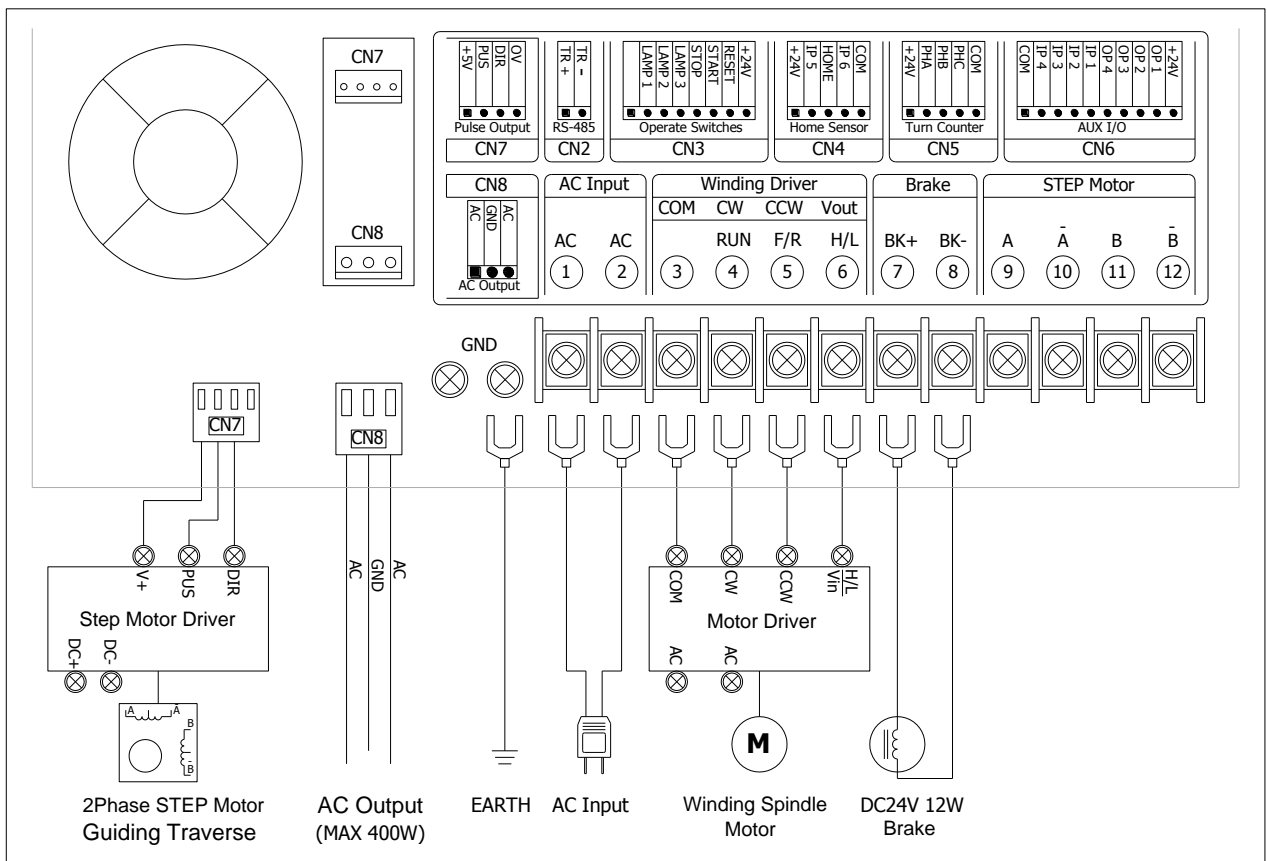

9. MAINTAIN AND TROUBLESHOOTING

9.1. Periodically maintain

- ◆ Please periodically clean up the controller inner accumulate dust and dopants.
- ◆ Please periodically check the wire connection between controller and machine if have loose or bad contact.
- ◆ The following parts must be maintained or changed periodically as list below. If any part is found faulty, it must be changed immediately even when it has not yet reached the end of its life, which depends on the operating method and environmental condition.
- ◆ For parts replacement, please contact your sales representative.

9.2. Error message

When a fault occurs during operation, the DATA DISPLAY shows error message, stop winding and then RESET go back to the READY mode.

Err-0 : The parameters or data in memory are fault.

Err-1 : The 『SHIFT』 value sets exceed the Travel Limit.

Err-2 : During winding, the guiding traverse to exceed the Travel Limit.

Err-3 : During winding, the guiding traverses reach to the Home sensor.

Err-p : Password error, key in 4 numbers password before edit.

9.3. To abort seeks the original position

At boot and reset procedures, if because of unknown reason however engender the winding shaft and guiding traverse can't find out the original position and make the controller can't get into ready mode, can press key to abort seeks the original position, make controller get into ready mode.

9.4. Troubleshooting

This section provides information to guide the user in understanding different fault condition and their general troubleshooting procedures, and with their possible solutions.

- ◆ **Do not connect or disconnect wires and connectors while power is applied to the controller.**
- ◆ **Make sure that the leads and connectors are connected correctly, before doing the troubleshooting procedures.**
- ◆ **Do not remove welded parts on the PC board without appropriate tools.**

NO	Fault Description	Correctives Action
1	Power ON, but the display shows nothing.	a. Check AC power input. b. Check the LED lamp on TLP-503D power supply, if not lit replace TLP-503D c. Replace 200A-CPU.

2	Power ON, but the display shows confusion message	a. Replace 200A-CPU.
3	Power ON, but winding spindle didn't rotate, or cannot stop rotation, And controller cannot get into ready mode.	a. Press STOP to make the controller get into READY mode. b. Check the winding parameter 『L.S.』 setting value of START STEP c. Replace turns counter CNTB-03B. d. Replace 200A-CPU.
4	Power ON, but guiding traverse didn't move or cannot stop moving, And controller cannot get into ready mode.	a. Press STOP to make the controller get into READY mode. b. Replace HOME SENSOR. c. Replace 200A-DVR. d. Replace 200A-CPU.
5	Cannot edit parameters.	a. Check the READY LED lamp if not lit, do procedures number 3 and 4. b. Key in four numbers password before edit, if the password has been set before. c. Replace 200-KBD. d. Replace 200A-CPU.
6	Display shows Err-0, then reset, and get into READY mode.	a. Replace 200A-CPU.
7	Display shows Err-1/Err-2 then reset and get into READY mode.	a. Check winding parameters 『SHIFT』 and 『WIDTH』 setting value. b. Check configurations 『TRAVEL LIMIT』 setting value.
8	Display shows Err-3, then reset, and get into READY mode.	a. Check winding parameters 『SHIFT』 and 『WIDTH』 setting value. b. Replace HOME SENSOR.
9	Brake failure.	a. Check wire connections of brake. b. Replace brake. c. Replace 200A-DVR.
10	Winding spindle can not switching winding direction.	a. Check configurations 『Winding spindle control mode selection』 setting value. b. Replace 200A-CPU.
11	Counting failure. Replace turns counter CNTB-03B.	Replace 200A-CPU.
12	Guiding traverse moves half pitch or double pitch.	Check Configurations 『Moving increment』 setting value.